



Spring Air

Solutions for Energy Savings

Enviro KES INSTALLATION MANUAL

Spring Air Systems Inc., Oakville, Ontario
Phone (905) 338-2999, Fax (905) 338-0179, info@springairsystems.com
www.springairsystems.com

KES Installation Manual.

This publication contains the installation instructions for standard KES units of the Spring Air Systems Inc. KES, KESF, KES-ISH Enviro units.

Carefully read this publication prior to any installation or maintenance procedure

Spring Air Systems catalogs; KES Engineering Manual, KES Maintenance Manual, KESF specification sheet, KES-ISH specification sheet, OP odour specification pellet sheet and OS odour spray specification sheet provide additional useful information describing the equipment, fan performance, available accessories, and specification data.

For additional safety information, refer to AMCA publication 410-96, Safety Practices for Users and Installers of Industrial and Commercial Fans. All of the publications listed above can be obtained from Spring Air systems by phoning (905) 338-2999, extension 29 or by FAX at (905) 338-0179; or by e-mail at info@springairsystems.com

For information on special equipment, contact Spring Air Systems Customer Service Department at (905) 338-2999 ext 28.

RECEIVING, HANDLING AND STORAGE

Spring Air System KES units have been carefully inspected before leaving the factory. When the unit is received, an on-site inspection should be made. The unit is factory balanced; all components (centrifugal wheel, shaft, bearings, etc.) have been tested prior to shipment. Units which are mishandled can void the warranty provisions. If units have been damaged in transit, it is the responsibility of the receiver to make all claims against the carrier.

Spring Air Systems is not responsible for damage incurred during shipment. Units should be handled with care to avoid possible damage. Severe jarring and/or dropping should be avoided. Units which are supplied with special painted or coated finishes should be handled with care to protect the surfaces. If continuity of the coating is scratched and damaged due to mishandling, the protective coating may be adversely affected. Long term storage requires special attention. All units should be stored on a level, solid surface (preferably indoors). If outside storage is necessary, protection against moisture and dirt should be provided. All bearings and shafts should be protected with lubricant and the entire unit should be encased in plastic or wrapped in some similar weather-proof material. To prevent deterioration of lubricants, special finishes, etc., periodic inspection should be made. During these inspections, it is good practice to rotate the centrifugal wheel by hand to spread bearing lubrication. It is advisable to remove V-belts if units are to be stored for an extended period of time. V-belts which remain under tension in a stationary position for extended periods are likely to have reduced operating life.

INSPECTION

Inspection of the KESF fan should be conducted first at time of receiving.

Ensure power supply is disconnected and locked out prior to performing maintenance

1. Inspect and tighten the fan wheel set screw after the first 30 minute, 8 hour and 24 hour intervals of satisfactory of operation and periodically thereafter.
2. Follow the motor manufacturer's instructions for motor lubrication. Remove any excess lubrication.
3. Drives:
 - A – Check belt tension and alignment, replace cracked or worn belts. If it is necessary to replace one belt on a multiple belt drive, replace all the belts with a matched set.
 - B – Under normal conditions, no re-lubrication is the rule. The bearing lubricant cavity is 1/3-1/2 filled as Shipped from the factory. Never lubricate new bearings.
 - C – Tighten set-screws on sheaves, wheel and bearing locking collars.
4. Clean the blower wheel. Material build up on the blades can cause wheel imbalance which, may result in wheel or motor bearing failure.
5. Generally, bearings should be lubricated at six to twelve month intervals. Recommended lubricants are: a) Imperial Oil – ESSO Beacon 325, or b) Shell Oil – Alvania Grease #3. A small amount of grease should be added slowly when the shaft is rotating. Note: Over greasing may cause damage to the bearing. Avoid rupturing the bearing seal.
6. To reinstall replacement ball bearings press the locking collar against the inner ring of the bearing and turn in the direction of the shaft rotation until engaged. Insert a drift pin into the pin hole and tap lightly to set. Tighten setscrew on locking collar firmly.

WARNING

This unit has rotating parts. Safety precautions should be exercised at all times during installation, operation, and maintenance. ALWAYS disconnect power prior to working on fan. Carefully inspect the fan and accessories for any damage and shortage immediately upon receipt of the fan.

- Turn the wheel by hand to ensure it turns freely and does not bind.
- Inspect dampers (if supplied) for free operation of all moving parts.
- Record on the Delivery Receipt any visible sign of damage.

HANDLING

Lift the KES Unit by the base or lifting eyes. Never lift by the top, sides or housing. No part of the KESF, KES filter box or complete unit can be rotated on to the side or roof without internal damage.

STORAGE

If the KES unit is stored for any length of time prior to installation, completely fill the KESF fan the bearings with grease or moisture inhibiting oil. Rotate the wheel several revolutions every three to five days to keep a coating of grease on all internal bearing parts. Store the KES unit in its original crate and protect it from rain, dust, debris and the weather.

OUTDOOR STORAGE

To maintain good working condition of the fan when it is stored outdoors, follow the additional instructions below.

- Coat the shaft with grease or a rust preventative compound.
- Wrap bearings for weather protection.
- Cover the inlet and outlet to prevent the accumulation of dirt and moisture in the housing.
- Periodically rotate the wheel and operate dampers (if supplied).
- Cover the any electrical components mounted on the outside of the housing to protect against the elements.
- Periodically inspect the unit to prevent damaging conditions.

PERSONAL SAFETY

Disconnect switches are always provided on the KES fan unit housing. The disconnect switch is near the fan in order that the power can be swiftly cut off in case of an emergency, and in order that maintenance personnel are provided complete control of the power source.

INSTALLATION

All KES units are shipped with motors mounted on the fans with belts and drives installed. However, extremely heavy motors and drives may be shipped separately. These motors and drives will require field installation. Examine the interior of the KESF fan unit prior to lifting/moving the KES unit to check motors have been shipped loose. When the motors and sheaves are mounted on the fan the fan and motor integral base is secured to the KES unit floor in two places. Do not remove these HOLD DOWNS until the KES unit is in its final position on the roof or in the building.

FOUNDATION

This KES unit requires a strong, level foundation. Sometime of reinforced poured concrete. A correctly designed concrete foundation provides the best means for mounting floor units. The foundation's size is determined by KES unit size and arrangement, and the specific location of the installation.

Use the following guidelines to calculate foundation size:

- The overall dimensions of the foundation should extend at least 6 inches beyond the outline of the KES unit.
- The weight of the foundation should be 2 to 3 times the weight of the KES unit.

DUCTED Installation

Efficient KES unit performance relies on the proper installation of inlet and discharge ducts. Be sure your KES unit conforms to the following guidelines.

NON-DUCTED discharge clearance:

The KES unit discharge must be placed 2 x the width of the KESF discharge away from walls and bulkheads. The KES unit must not discharge into or near a fresh air inlet. Even with odour control the odours may be drawn back into the building at some time during operation.

DUCTED discharge:

Where possible, allow 3 KES unit discharge duct widths between duct turns or elbows and the KES outlet. The KESF exhaust fan inlet ductwork from the KES filter box (in some jurisdictions) can be connected using heavy duty HVAC duct able to withstand 6"W.C. static pressure. Otherwise the inlet duct must be continuously welded to the KESF fan inlet.

DUCTED Inlets:

The inlet ductwork does not require and special distance between the KES unit inlet and an elbow or turn in the inlet ductwork. The inlet ductwork must be continuously welded to the KES filter box from the hood(s). The KES filter box discharge (in some jurisdictions) can be connected to the KESF unit with heavy duty HVAC duct able to withstand 6"W.C. static pressure.

CURBS:

The curb is installed on the roof of the structure first. A hole is cut to match the inside dimensions of the curb. Then the curb is set in place on top of this hole. The curb must be securely fastened to the roof structure around the 3" bottom perimeter flange. The connection must be sealed water tight.

Local codes may dictate additional or modifications to this installation. The installation diagram below has a curb installed on the roof deck. The curb is shipped knocked down and to be assembled by the local installing contractor. The 16gas curb is supplied with bolts to assembly prior to placing the curb on the roof. See isometric of assembling the curb below.

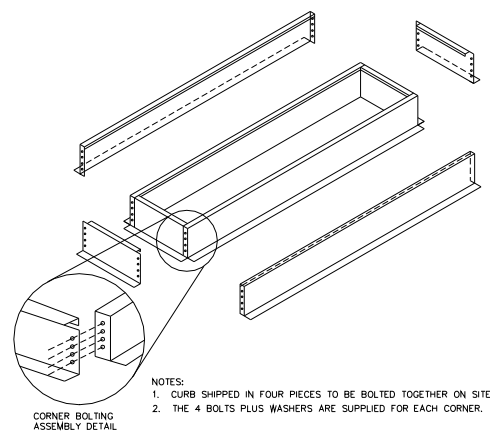

ISOMETRIC OF ASSEMBLING CURB

Apply a silicone sealant to the top outside perimeter of the curb and set the complete KES unit on the curb. The unit weight should be enough to hold the unit firmly on the curb. Then welded grease duct from the hoods passes through the KES bottom exhaust inlet and is continuously welded to the bottom standing flange in KES unit. See sketch below.

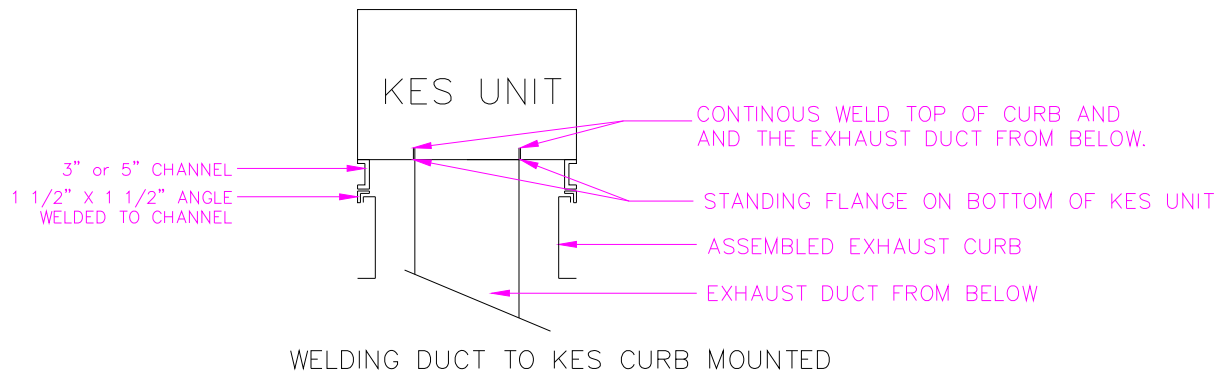

INDOOR INSTALLATIONS

When moving the KES and its components into the building support each end using the lifting points indicated on the drawings. Failure to do this will cause internal damage. When picking up either end of the unit from the lifting points use a splitter bar to ensure that housing and doors are not damaged while moving.

The KES unit may be shipped one or two pieces depending on access into the building.

Field Connect the together the two pieces: KES-ISH filter box and KESF fan box

1. Move the two pieces to the location where they are to be installed. Uncrate the filter and fan box and place on a level surface. Align the KES-ISH filter box discharge (This is the end with the fire damper in the duct collar) so that it is facing the KESF fan unit inlet. There is a neoprene gasket attached to the KES-ISH filter box inside standing flange. Check to ensure that it is still in place on the flange inside the boltholes pattern. If parts of the gasket have been removed, reseal them with silicone.
2. Remove the nuts, bolts and lock washers from a box in the KESF fan section.
3. Slide the KESF inlet fan section into the KES-ISH filter box.
4. Align the bolts holes on the top and lower side exterior standing flange of the KES-ISH filter unit and KESF fan unit. Insert the four bolts. One in each of the top corners and one in each of the bottom sides of the KES-ISH filter and KESF fan section. Place lock washers and nuts on the end of the bolts and tighten each corner. Check periodically that the other boltholes remain aligned.
5. Enter the unit through the KES-ISH filter section box filter access door and insert the bolts and nuts into the standing flange at the bottom of the KES-ISH filter and KESF fan unit. Tighten these nuts and bolts uniformly.
6. Insert bolts into each side of the base flanges where the exterior bases of KES-ISH filter and KESF fan unit meet. The base is at the outside lifting point of the two pieces.
7. Continue to insert the bolts, lock washer, and nuts in the remaining boltholes connecting the KES-ISH filter and KESF fan box. It is best to start in the middle of the top and ends and work back towards the corners.

- Reconnect the electrical connection from KES-ISH LV10/LV20 panel to the KESF motor starter/VFD. The original connection was made in the factory and disconnected for shipment.

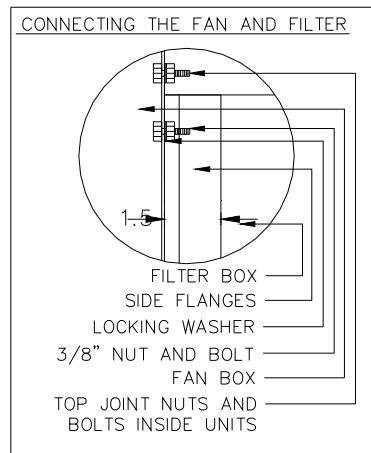

Hanging the KES-ISH filter and KESF filter box.

- If required complete the Field Connection of the KES-ISH filter box and KESF fan section
- Once the pieces are together forming one unit the complete assembly can be suspending from the lifting points indicated on the dimensional drawings.
- The total weight of the assembly is the weight of the KES-ISH unit plus the weight of the KESF fan unit. The weight distribution is outline below as a percentage of the weight of each piece.
- The unit is suspending on six (6) hanging threaded rods through the holes in the web of the lifting flanges. Secure a bolt and lock washer to the end of each threaded rod under the unit flanges. Size the rods to hold the weight calculated for each rod below.

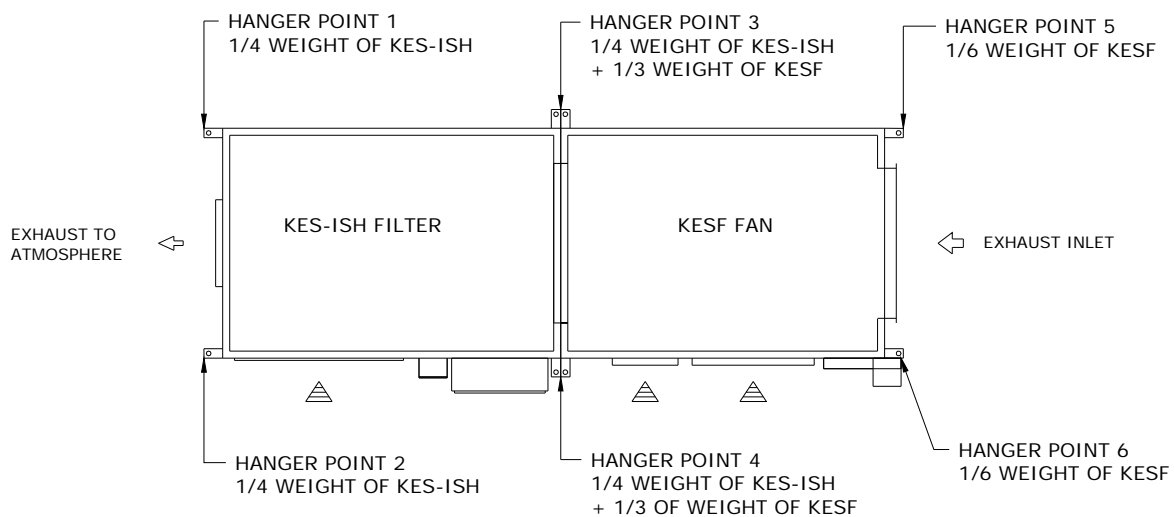

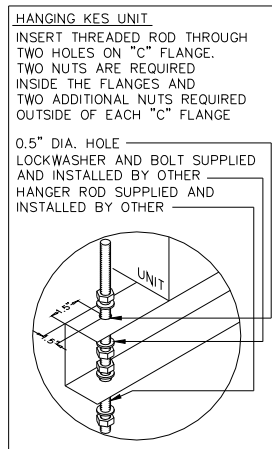

The sketch above outlines the proper procedure to install the hanging rod to the KES typical lifting point.

WIRING

Review all factory wiring drawings of external and internal wiring for the KES unit. Work must be completed by a qualified electrician. All wiring should be in accordance with local ordinances and the National Electrical Code, State, Provincial or Municipal codes... Ensure the power supply (voltage, frequency, and current carrying capacity of wires) is in accordance with the KES nameplate. Lock off all power sources before unit is wired to power source. Leave enough slack in the wiring to allow for movement.

VARIABLE FREQUENCY DRIVES.

Grounding -

The fan frame, motor and VFD must be connected to a common earth ground to prevent transient voltages from damaging rotating elements.

DRIVE WIRING

Line reactors may be required to reduce over-voltage spikes in the motors. Line reactors are supplied by installing electrician. Spring Air Systems should be consulted for recommended line impedance and usage of line reactors or filters, if the lead length between the VFD and the motor exceeds 10 feet (3m).

Fan -It is the responsibility of the installing contractor to perform coast-down tests and identify any resonant frequencies after the equipment is fully installed. These resonant frequencies are to be removed from the operating range of the fan by using the "skip frequency" function in the VFD programming. Failure to remove resonant frequencies from the operating range will decrease the operating life of the fan and void the warranty.

CLEARANCES:

The body of the KESF filter box or Complete KES is to be treated as if it is an extension of the commercial kitchen welded duct from the hood. Requirements are 18" to combustibles, 3" to limited combustibles and 0" to combustible surfaces.

All KES access doors are hinged and swing open. The doors require a minimum 36" clears for removal of filters, fans, motors, or drives unless some special design have be made to reduce this clearance.

AFTER INSTALLATION

Once all ducting and wiring have been completed refer to the KES maintenance manual for start-up Procedures. The KES Unit start-up must be performed by a qualified Spring Air Systems service representative.

Other Fine Products From

SPRING AIR SYSTEMS...

- Water Wash Ventilators
 - ◆ Hot Water Wash
 - ◆ Cold Water Spray/Hot Water Wash
 - ◆ Water Wash Control Panels
- Dry Extractor Hoods
- **RevLow** Hoods
- **Dynaflow** Hoods
- Cartridge Hoods
- Filter Hoods
- Surface Fire Suppression
- Commercial Kitchen Exhaust Fans
- Kitchen Enviro Systems
 - ◆ KES - 100% Exhaust
 - ◆ KRS - 80% Recirculation in Canada
- Commercial Kitchen Supply Units
- Compensating Hoods
- Exhaust Fans
- **Zoneflow** Kitchen Exhaust Balancing Dampers
- Supply Fans
- Commercial Kitchen Control Panels
- TruFlow Variable Speed Exhaust/Supply Systems
- Utility Distributions Systems