



# KES Enviro

(With MXFLO)

## Maintenance Manual

---

January 08

Spring Air Systems Inc.

Phone (905) 338-2999, Fax (905) 338-0179, [info@springairsystems.com](mailto:info@springairsystems.com)

[www.springairsystems.com](http://www.springairsystems.com)

# KES Enviro Maintenance Manual

## Table of Contents

Introduction	1
The System	1
Control Circuit	3
Control Systems: Dry Hoods	8
Control System: Water wash	10
MXFLOW Option	13
Checking Fan Rotation with MXFLOW Option	15
Changing the Exhaust Volume with MXFLOW Option	16
Odor Spray System	17
Where to Purchase Filters	19
Replacement Filter Equivalents	19
When to Change the KES Filters	20
Trouble Shooting	22
KES Maintenance Schedule	24
Appendix A: MXFLOW only: Setting the DMP	26
Appendix B: MXFLOW only: Factory Drive Terminal Schematic	28
Appendix C: Hazardous Warning	30
Appendix D: MXFLOW only: Good Wiring Practice	31
Appendix E: MXFLOW only: Grounding	32
Appendix F: MXFLOW only: Starting the Drive	33
Appendix G: MXFLOW only: Accessing the drive program menu	34
Appendix H: MXFLOW only: Programming the Drive Parameters	36
Appendix I: MXFLOW only: Trouble Shooting the Drive Fault Display	37
Appendix J: MXFLOW Factory wiring	42
Appendix K: Programming the SMART clock	43
Appendix L: Setting the Filter Out and Filter Clogged in PLC	46
Appendix M: KES Logo Factory Wiring Diagram	52
KES Enviro Start-Up Report	53

Jan08

# KES ENVIRO OPERATION AND MAINTENANCE MANUAL

## INTRODUCTION

Thank you for purchasing a Spring Air Systems commercial kitchen ventilation product. Please read the complete “KES Enviro Operation and Maintenance Manual” prior to installation, commissioning or operating a KES unit.

The SPRING AIR SYSTEMS INC. kitchen Enviro system (KES), Exhaust Cleaning Assembly for Kitchen Exhaust Duct, “Enviro Unit” is ULC and UL listed for use in a commercial kitchen exhaust system. KES units are available in sizes ranging from 1,000 CFM to 40,000 CFM for indoor or outdoor applications.

The primary function of a KES Enviro unit is to filter the grease, lint and dust particles and remove the odor from the exhaust air.

The Underwriters Laboratories Inc. (UL) and Underwriters’ Laboratories of Canada Limited (ULC) listings allow the kitchen exhaust air to be discharge to atmosphere at low levels.

**Prior to any installation the installer must seek approval from the authorities having jurisdiction.**



KES-ISH Enviro Filter Box  
Figure 1



KESF Enviro Fan Box  
Figure 2

## THE SYSTEM

The grease-laden air rises from the cooking equipment into a UL or ULC exhaust hood. The exhaust hood removes some of the airborne grease particulate. Typically most micron and submicron particles escape into the exhaust ductwork. The exhaust ducting is connected from the hood to the inlet of the KES Enviro unit. This exhaust ductwork must be supplied and installed in accordance with the NFPA-96 code.

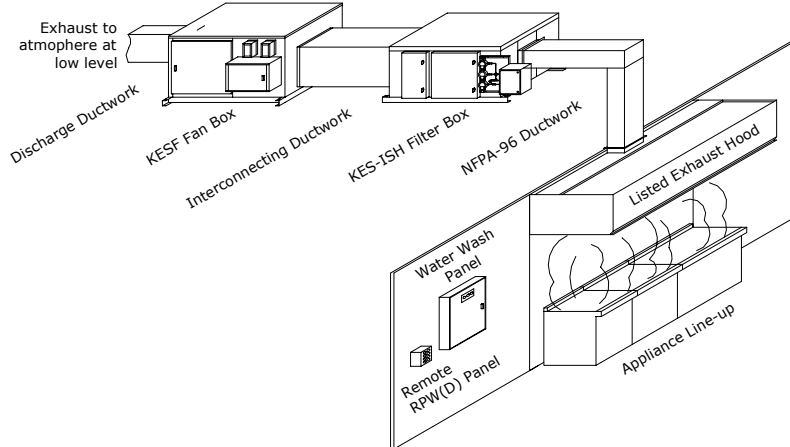

KES System Schematic  
Figure 3

Once through the particulate filter sections the exhaust air enters the optional odor removal section. The odor section is only required when discharging cooking smells may be offensive. This section consists of two optional odor removal systems.

1. Odor Cells filled with activated alumina impregnated with potassium permanganate. The odor is controlled through a combination of sorption and the chemical modification of the gaseous contaminates. The odor media is non-toxic and non-flammable.
2. Odor spray solution. The odor is control by spraying an odor reducer into the exhaust air stream intermittently during the operation of the cooking systems. The odor spray unit is normally located mounted on the KESF fan section. The cabinet includes an air compressor, atomizing air nozzle and piping and odor spray container.



*Odor Spray components  
Figure 4*

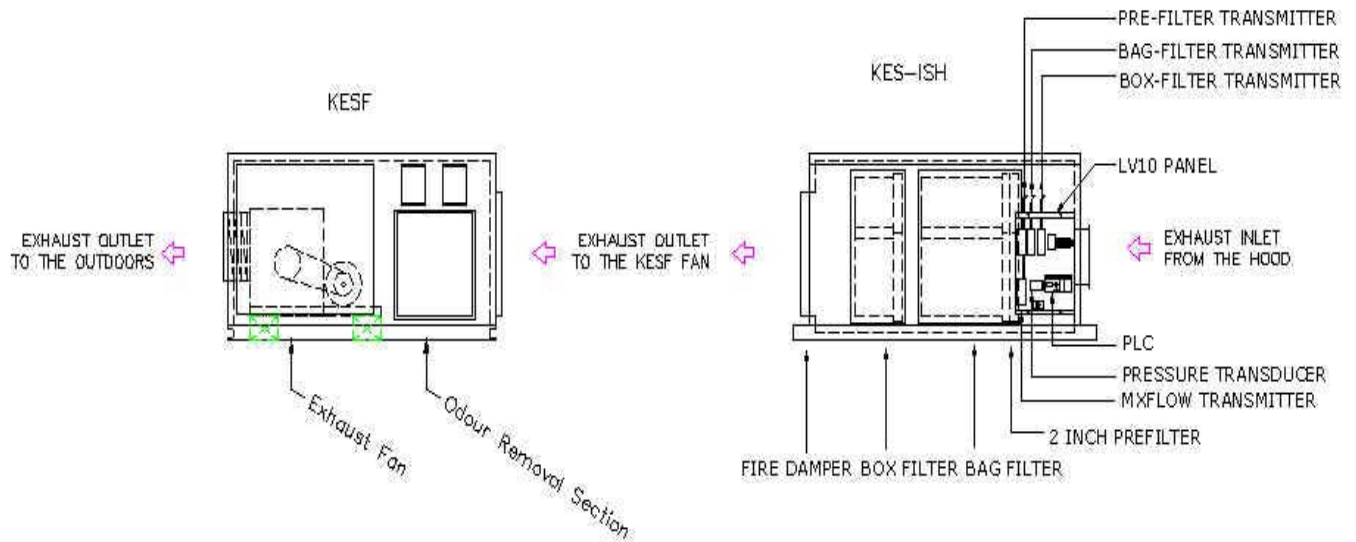

*KES-ISH and KESF Enviro components  
Figure 5*

The exhaust air is discharged from the KES unit through a single width, single inlet (SWSI) or double width, double inlet (DWDI) exhaust fan. The discharge ductwork transfers the exhaust air outdoors.

# CONTROL CIRCUIT

## **Filter Clogged:**

During normal operation of the KES unit three-filter stages collect grease, dust, and lint particulate. The type of cooking equipment and the hours of operation determines the useful life of the individual filters.

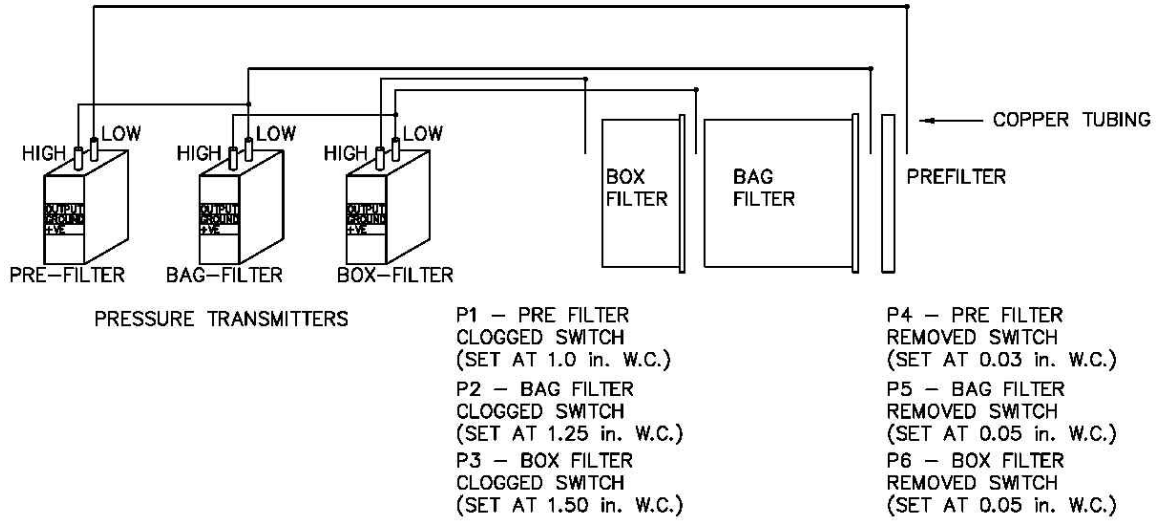

*Pressure Transmitter Locations  
Figure 6*



*Box Filter probes as viewed from discharge  
Figure 7*

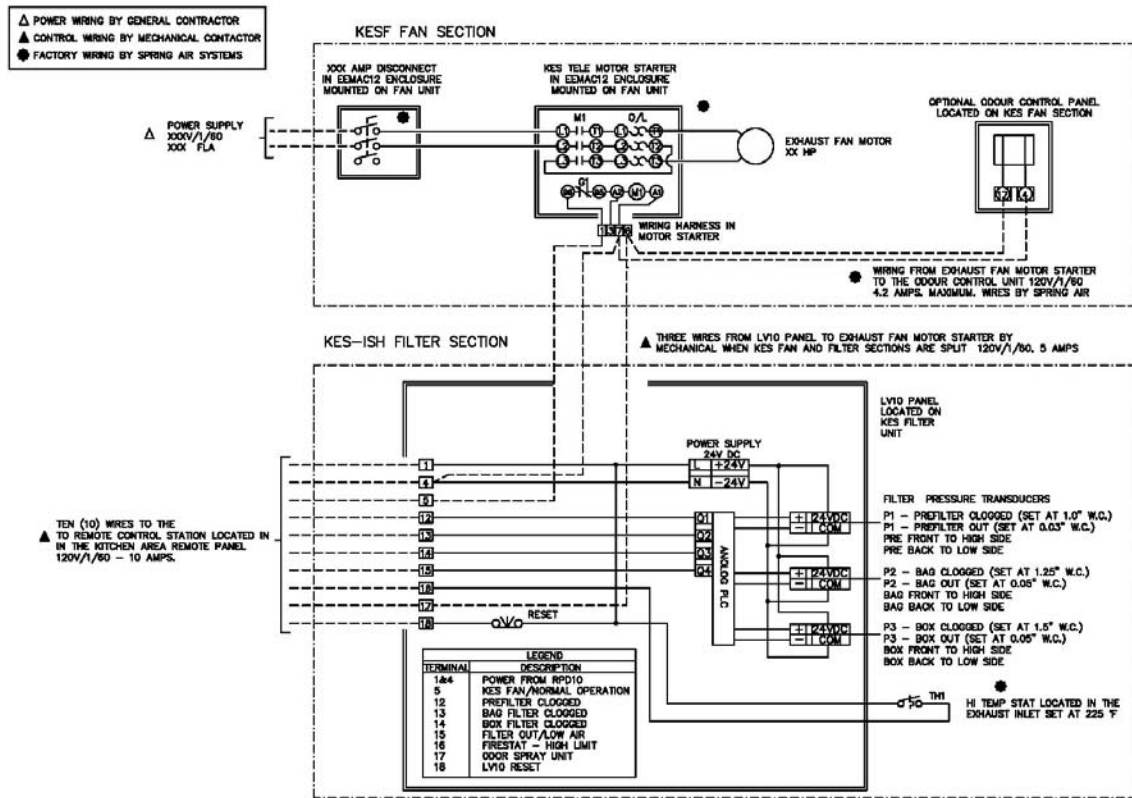

Typical indoor KES, motor starter, LV10 J-Box with odor spray wiring schematic  
Figure 8

Pressure transducers determine when the filters are totally used and must be replaced. As the filter reaches the grease loading capacity the static pressure across each filter increases. When the maximum static pressure is reached the transducer activated a PLC output.. The exhaust fan shuts off, the "NORMAL" pilot energizes, and the kitchen remote panel annunciates a filter-clogged condition. (The remote panel indicates which stage of filters has clogged; PREFILTER, BAG FILTER, or BOX FILTER.) In addition the screen of the PLC in the RPD-KD or RPD-KW has a text message also indicating which filter is clogged.

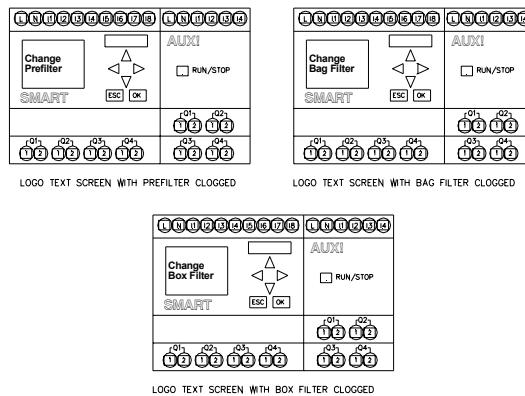

RPD-KD or RPD-KW PLC indicating Box Filter clogged text messages  
Figure 9

The clogged filter must be replaced and the system reset to resume normal operation. If this condition occurs during normally operating hours rotate the OVERRIDE selector switch and the fan will come back on. The systems can run in the OVERRIDE position for about 4 hours. (See the section the OVERRIDE switch) If the system runs longer than 4 hours the fan will shut down. The filters must be changed and the system reset. It is recommended that the filters be changed prior to the filter clogged light energizing. A filter usage chart is attached to record when the filters are being changed. Using this chart a regular maintenance schedule can be set up to ensure constant uninterrupted operation of the commercial kitchen.

**Filter Removed:**

Should the bag or box filters be removed during normal operation the KES unit is automatically shutdown. A pressure transducer measuring static pressure across the bag filters and box filters monitors a minimum pressure drop of 0.05" W.C. When the filter is removed the pressure differential falls and the pressure switch is activated. The exhaust fan shuts off, the "FILTER REMOVED" pilot light on the RPD-KD or RPD-KW energizes and the screen of the PLC in the RPD-KD or RPD-KW has a text message indicating "FILTER REMOVED/LOW EXHAUST. To resume normal operation the filter must be replaced and the system reset. (See the section the OVERRIDE switch)

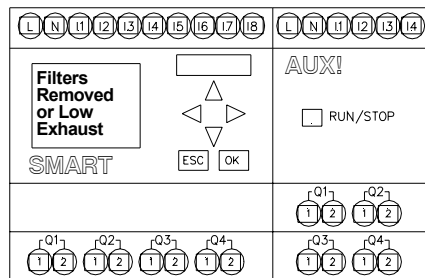

*RPD-KD or RPD-KW PLC indicating filter removed text message  
Figure 10*

**High Temperature:**

In the event of a high temperature in the ductwork leading to the KES unit or within the KES unit a firestat located at the inlet of the KES filter section is activated. When the exhaust air reaches 160 F the firestat is energized. The exhaust fan shuts off, the "NORMAL" pilot goes off, and a "FIRE" pilot energizes on the remote RPD-KD or RPD-KW panel. Should the exhaust temperature continue to rise the fusible link melts and closes the fire damper in the exhaust discharge of the KES filter section. This fire damper is always located between the fan and filter section. The fire damper fusible link is rated at 165 F. Shut off all cooking equipment and notify the fire department. To resume normal operation, replace the fusible link and reset the system. An authorized SPRING AIR SYSTEM INC. service technician should be called to inspect the unit.

**Override Switch: (located on RPD-KW or RPD-KD panel)**

In the event that the filter clogged annunciation shuts off the KES unit during a peak cooking time rotate the OVERRIDE SWITCH located on the RPD-KW panel clockwise. The WARNING pilot light will energize and the FILTER CLOGGED and NORMAL lights will turn off. This is a temporary override to allow for the cooking equipment to be shut off prior to changing the filters. The systems can run in the OVERRIDE position for 4 hours. If the system runs longer than 4 hours the fan will shut down. The filters must be changed and the system reset. It is recommended that the filters be changed prior to the filter clogged light energizing. A filter usage chart is attached to record when the filters are being changed. Using this chart a regular maintenance schedule can be set up to ensure constant uninterrupted operation of the commercial kitchen.

Once the dirty filter has been replaced rotate the OVERRIDE SWITCH to counter clock wise to resume normal operation.



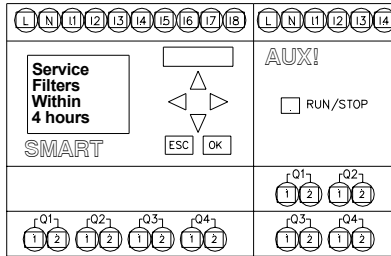

RPD-KD or RPD-KW LOGO with Override selector in on position  
 Figure 11

**System Reset:**

After any of the safety circuit annunciation, the system must be reset. The system is reset by toggling the “RESET” switch in the LV10 J-box, or switching the OVERRIDE SWITCH on the RPD-KW or RPD-KD, or turning the fan selector switch to the “OFF” and then to the “ON” position.



RPD-KW and RPD-KD Logo Processor  
 Figure 12





RPD-KD Face Plate  
Figure 13



RPD-KW Face Plate  
Figure 14

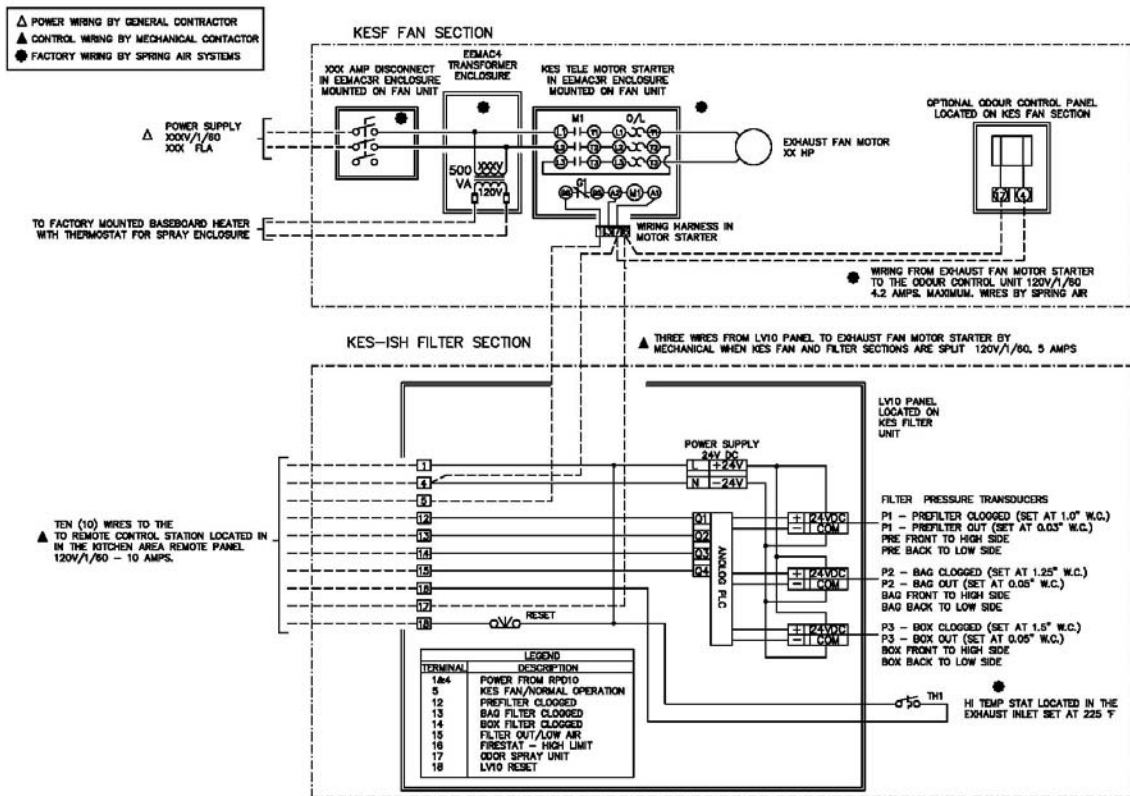

Wiring diagram for Outdoor KES, motor starter, LV10 J-Box, and odor unit  
Figure 15

# CONTROL SYSTEM

## Dry Hoods:

### RPD-KD Remote Panel

The KES unit off/on operation is controlled from RPD-KD remote annunciation panel. The fan selector switch on the RPD-KD remote panel closes and sends power through terminals 5 & 4 to the LV10 J-Box to energize the exhaust fan circuit. (The LV10 J-Box is mounted on the KES-ISH filter section). The "NORMAL" operation pilot on the RPD-KD remote kitchen annunciation panel energizes and after 30 seconds the KES control circuit within the RPD-KD remote panel is activated. The exhaust fan motor is energized through the terminals 5 & 4 to the motor starter. See figure 8 for the RPD-KD remote panel wiring and figure 9 for dimensions.

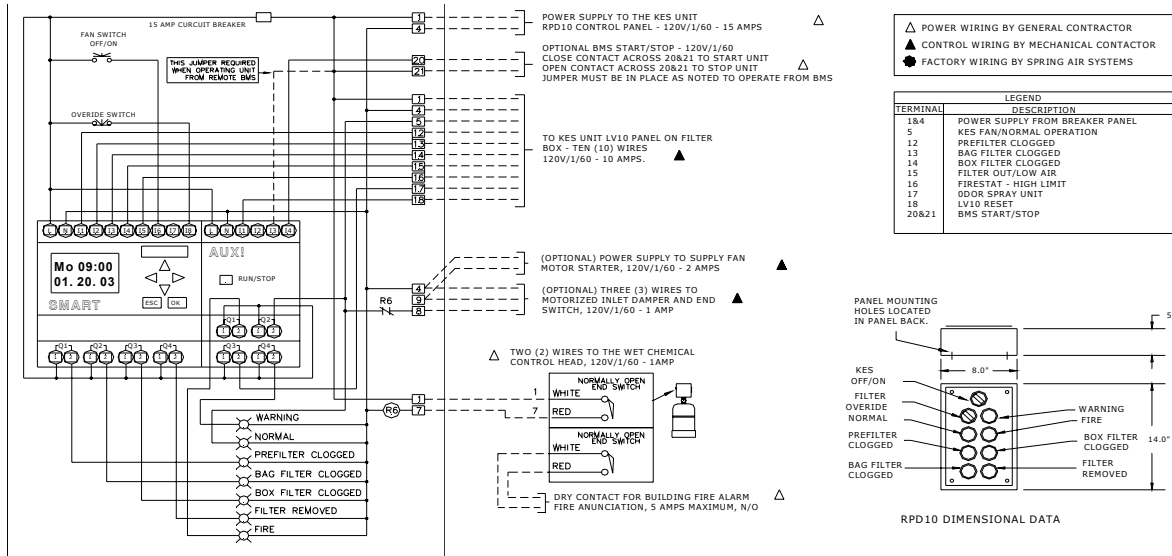

RPD-KD Wiring Schematic  
Figure 16

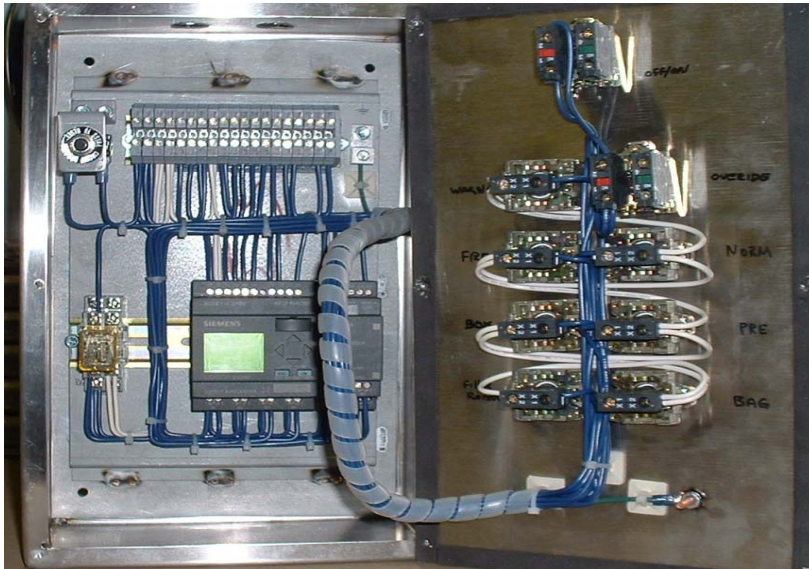

RPD-KD Internal Wiring  
Figure 17

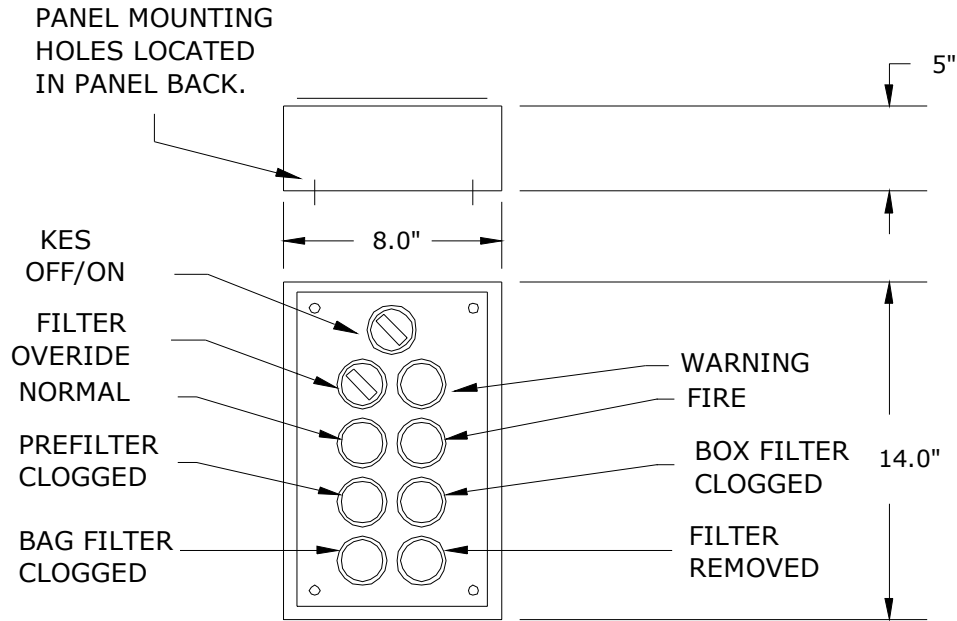

*RPD-KD Remote Panel Dimensions  
Figure 18*

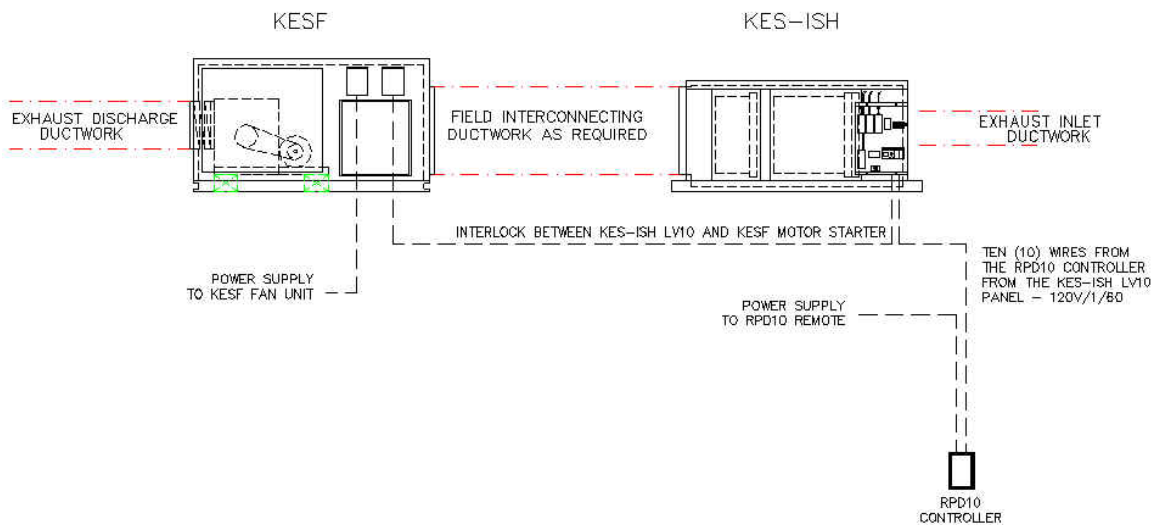

*Remote wiring of KES Enviro units with Dry Hood  
Figure 19*

# WATER WASH HOODS

## Water Wash Ventilator System: SB, SBA Panels

The KES unit off/on operation is controlled from the SB, or SBA water wash ventilator control panel. Power is fed to the RPD-KW panel through terminals 1 & 4. When the fan selector switch on the water wash control panel closes a signal is sent through terminal 3 to the RPD-KW panel to activate the KES unit.

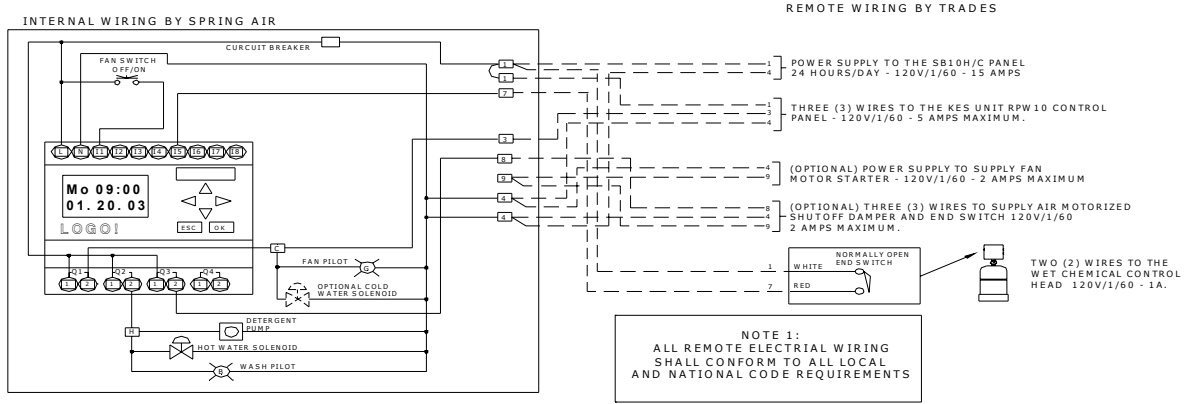

Typical KES wiring to SB10C water wash panel  
Figure 20

The “NORMAL” operation pilot energizes on the RPD-KW remote kitchen annunciation panel. After 30 seconds the RPD-KW control circuit is activated. The RPD-KW is a stainless steel panel located remote from the SB or SBA panel. See Figure 5 for RPD-KW wiring and dimensions. The KES exhaust fan motor is energized through the terminals 5 & 4 to the LV10 J-Box located on the KESF fan section. See figure 11 for internal wiring of the LV10 J-box. See figure 3 or 5 for a SB water wash panel.

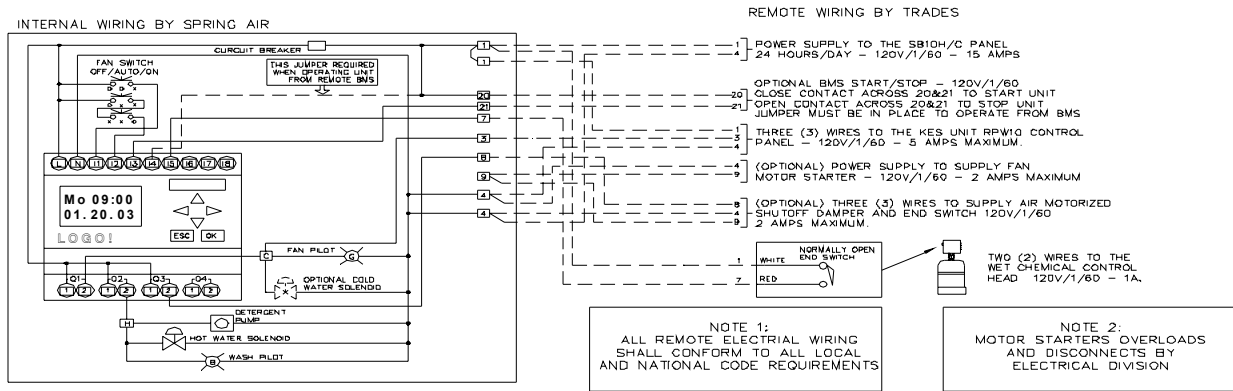

Typical KES wiring to SBA10C water wash panel  
Figure 21

RPW10 ELECTRICAL DATA

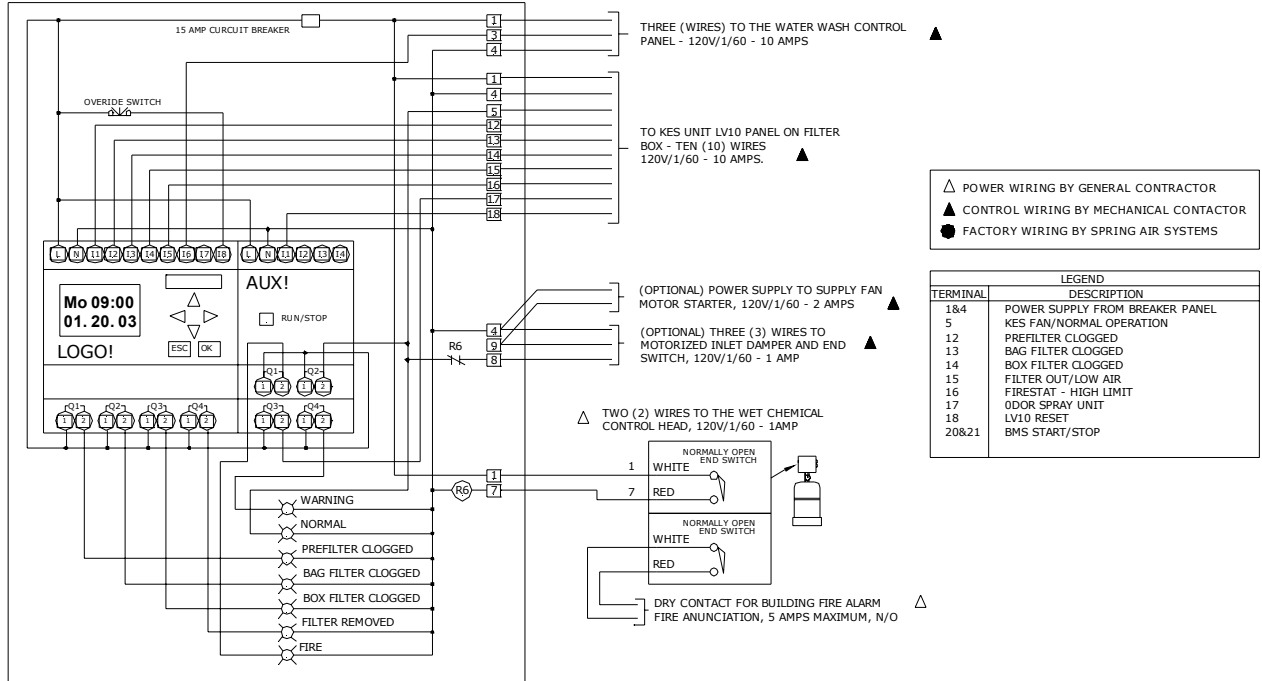

RPD-KW Wiring Schematic  
Figure 22

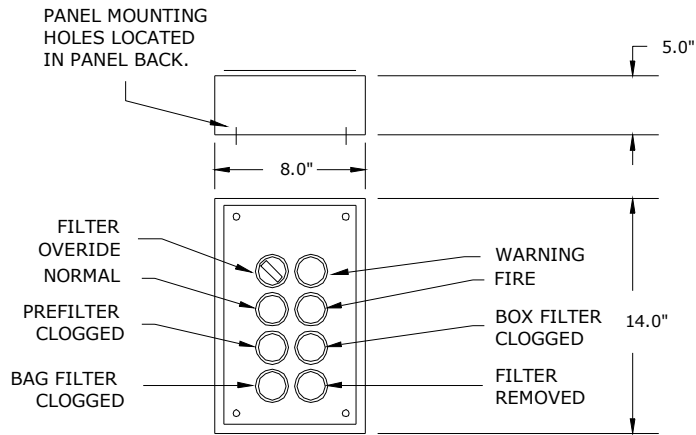

Remote RPD-KW Panel Dimensions  
Figure 23

## Water Wash Ventilator System: AP, MP Panels

The KES unit off/on operation is controlled from the MP or AP water wash ventilator control panel. The fan selector switch on the water wash control panel closes and sends power through terminals 3 & 4 to the RPD-KW remote panel to energize the exhaust fan through terminals 5 & 4 in the LV-10 J-Box. (The LV10 J-Box is mounted on the KES-ISH filter section).

The "NORMAL" operation pilot energizes on the RPD-KW. After 30 seconds the KES control circuit within the RPD-KW remote panel is activated. See Figure 5 for RPD-KW internal wiring. The exhaust fan motor is energized through the terminals 9 & 4 to the motor starter located on the KESF fan section. See figure 11 for internal wiring of LV10 J-Box with RPD-KW remote panel. When the MXFLOW is incorporated in the KES a relay is activated off the same circuit causing the drive to run.

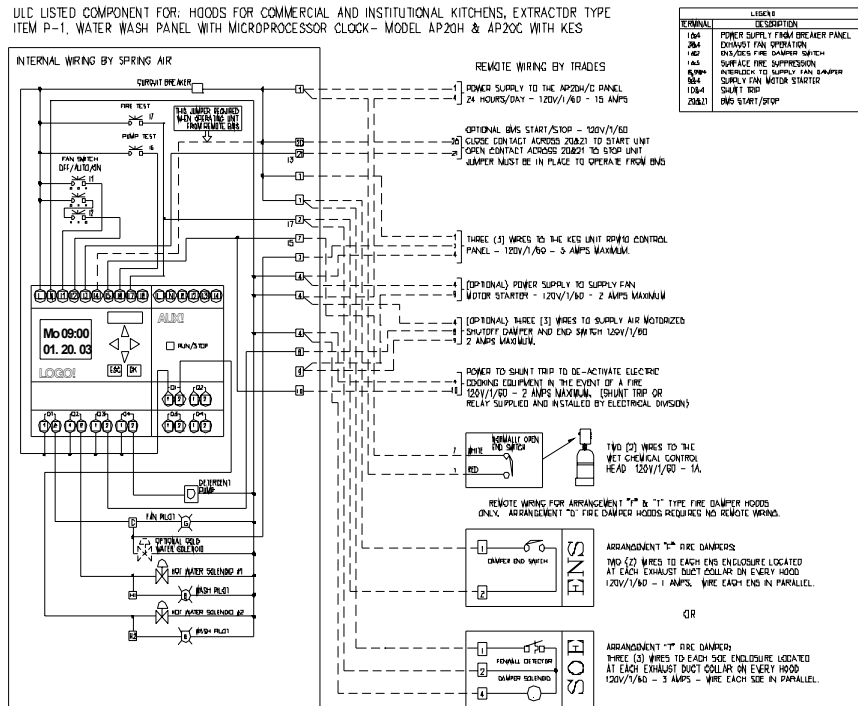

Typical KES wiring to AP20C water wash panel  
Figure 24

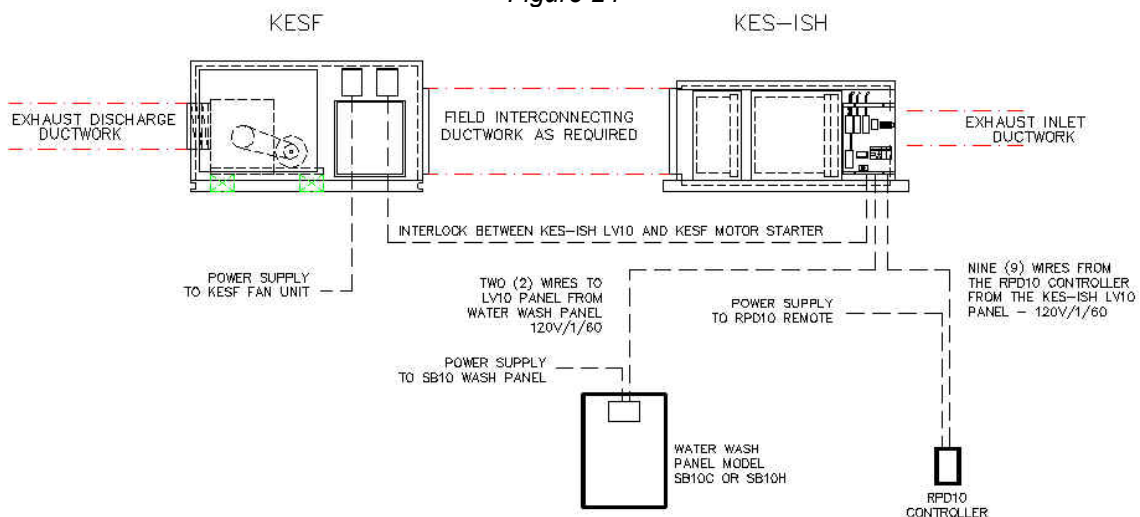

Remote wiring of KES Enviro units with Water Wash Hood and Panel  
Figure 25

## MXFLOW OPTION

### INCREASING FILTER LIFE

MXFLOW is designed to increase filter life while maintaining maximum exhaust volume during the commercial kitchen cooking operation. Immediately after commissioning the KES unit the exhaust air volume is at the highest level. As each of the three filter banks captures grease particulate of micron and submicron size they begin to fill and the air resistance through each filter increases. Even though the KESF unit has a heavy duty, Class II, backward inclined fan the increase in combined resistance (static pressure “W.C.”) through each filter will gradually reduce the exhaust volume. In cases where there is very heavy cooking with large quantities of micron and submicron grease particulate the reduced exhaust volume is most noticeable. In some cases the filters may have to be changed not because the filter is clogged but because the combined static pressure resistance through all the filters has reduced the exhaust volume enough to affect smoke capture. This is less of a problem with lighter cooking operations.

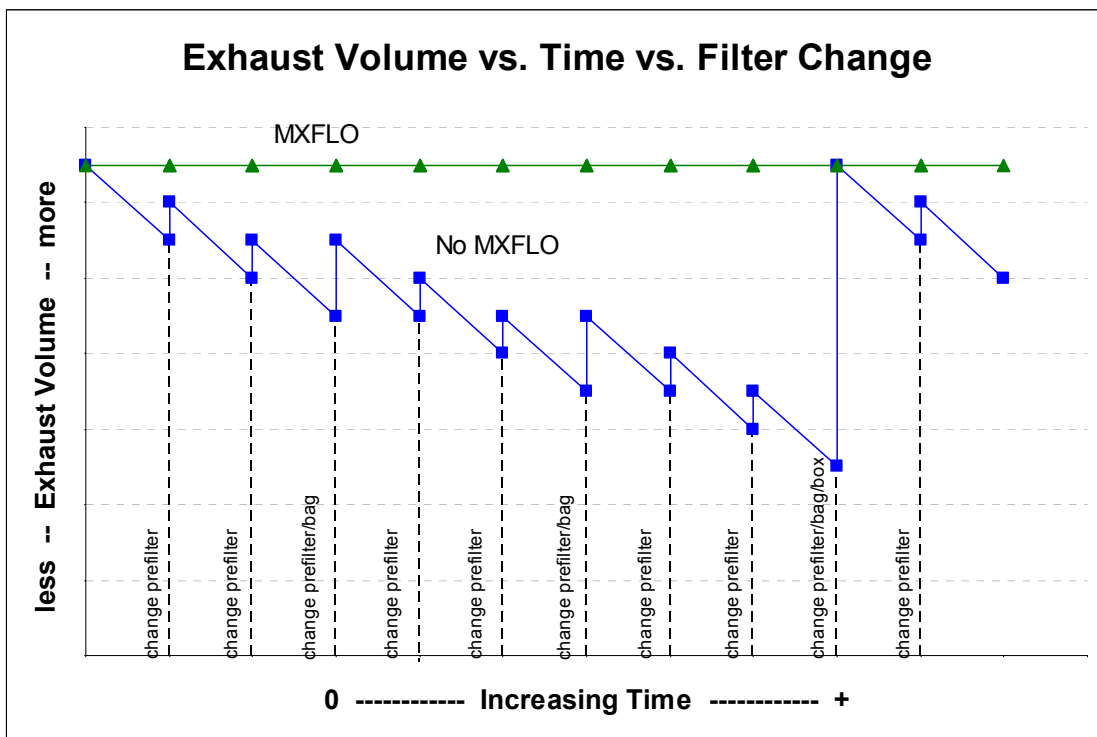

Figure 26

In the example above the “No MXFLOW” KES unit exhaust volume (shown in BLUE) gradually drops as the filters become increasingly clogged. Even when the prefilters and bag filters are replaced the exhaust volume does not return to maximum because the box filter continues to clog. This drop in exhaust volume generally only represents about 10% of the total exhaust volume. But in some cases this can be enough to affect the hoods ability to capture smoke adequately.

The “MXFLOW” KES unit incorporates a combination pressure transducer/microprocessor and variable speed drive to maintain constant exhaust volume regardless of the increased static pressure through any of the particulate filters. As the pressure across any filter increases and the exhaust volume decreases the pressure transducer/microprocessor senses this change and automatically increases the exhaust fan speed to compensate for this increased static pressure to maintain a constant exhaust volume.



MAXFLOW also allows for one touch exhaust volume adjustment when commissioning the unit; thereby making commissioning a more straightforward process. Additionally, MAXFLOW eliminated the need to change sheaves. If the exhaust volume has to be field adjusted because of an appliance change or ductwork change the MAXFLOW provides automatic exhaust volume adjustment, up or down, with the touch of a single button.

## MAXFLOW WIRING Diagram

The MAXFLOW is factory installed and tested prior to shipment. The components consist of the MAXFLOW control panel model LV20 in conjunction with an exhaust fan motor variable speed controller.

ELECTRICAL SCHEMATIC, OUTDOOR KES LV10 & LV20 TERMINAL BOX, & ODOR SPRAY, INDOOR KES ENVIRO MOTOR CONTROL AND ANNUNCIATION CIRCUIT  
CSA CERTIFIED

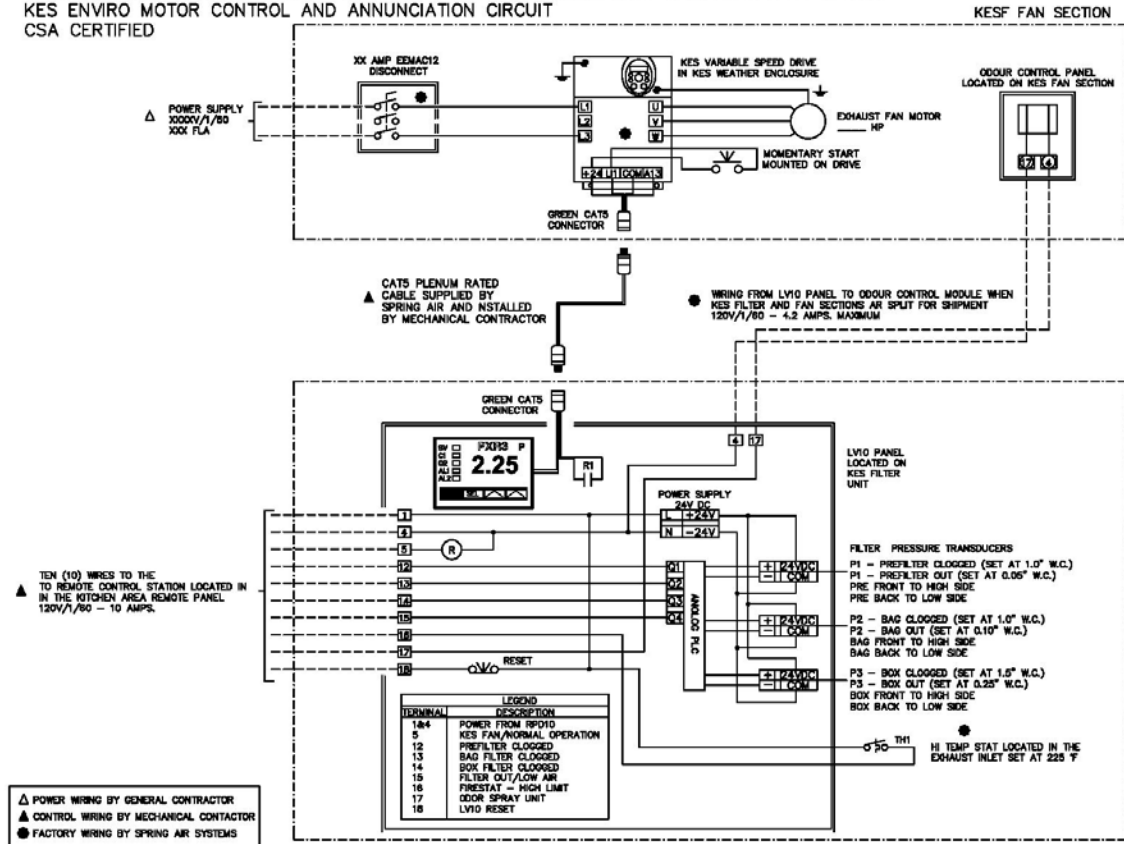

Standard MAXFLOW wiring diagram with indoor KES LV10 panel and odour spray option  
Figure 27



*Inside the LV10 panel with MXFLOW  
Figure 28*

The MXFLOW components are located in the LV10 panel with the filter transmitters and the PLC. The MXFLOW components include the pressure transducer (PT), digital micro-processor (DMP), momentary pushbutton, start relay and 24Volt power supply. When the operator rotates the unit selector switch to the on position power is supplied to the KES LV10 panel through terminal 5. Terminal 5 activates relay R1 which closes a dry contact across the exhaust motor variable speed drive terminals +24V and LI1. The exhaust fan motor starts. In addition the 24V power supply activates both the digital readout on the micro-processor and the PT. The (+ve) pressure port on the PT is vented to atmosphere and the (-ve) pressure port is piped into the inlet of the KES-ISH filter box. The probes measure the external static pressure on the inlet of the KES-ISH filter box. The DMP is factory set to the total static pressure as indicated on the KES LV10 drawing. Figure 28 shows the inside of the LV10 panel. The PT is located at the bottom of the LV10 panel with the pressure probes existing from the right end at the bottom. One probe enters the unit casing and the other is vented to atmosphere. Directly above the PT is the power supply, on/off relay and terminal block. The DMP is mounted on the door panel.

### **Operation**

As a filter clogs, the pressure drop through the filter increases, decreasing the exhaust air volume, and decreasing the static pressure measured at the PT. The PT sends a signal to the DMP to increase the static pressure back to the set point by increasing fan speed. The result is a constant exhaust volume until the filters are full and must be replaced.

### **CHECKING FAN ROTATION**

Fan rotation should be checked prior to commission the system. Turn the fan selector switch in to the off position. Turn on the circuit breaker powering the KESF unit. To check fan rotation press the momentary button located on the MXFLOW LV20 panel. The fan will start for as long as the button is pressed. The backward inclined KESF fan must be running backwards such that the fan blades pushing the air from the back of the blade. If the fan is scooping the air change the fan rotation. To correct fan rotation switch two of the high voltage wires on terminals V/T1, U/T2 or W/T3 on the drive or switch two wires at the motor.

**SHUT OF ALL POWER TO THE KESF BEFORE CORRECTING ROTATION**



*A KESF DWDI fan. Correct rotation for this fan arrangement looking into the end shown above is clockwise  
Figure 29*

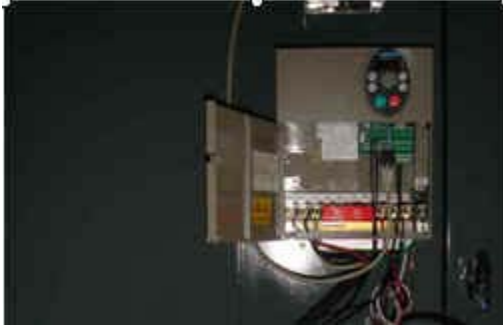

The momentary pushbutton is located on the side cover of the variable speed drive as indicated in figure 26. The button is a small black button located beside the terminal strip.

The exhaust motor variable speed drive is located on the KESF fan section below the disconnect switch

*Variable Speed drive mounted on side of the KESF unit.  
Figure 30*

## CHANGING EXHAUST AIR VOLUME ON SITE

With the MXFLOW system changing the exhaust air volume on site is a simple and easy task. First complete the startup report attached in the back of this manual. Once the report has been completed and the system is operating satisfactory measure the actual exhaust air volume using the appropriate air flow measuring device.

The exhaust air volume can be adjusted approximately +/- 15% from the factory setting with the touch of a button.

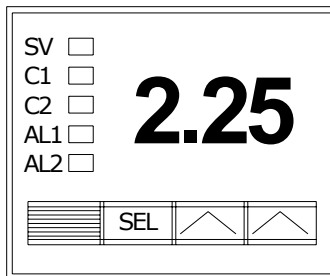

To adjust the exhaust volume, press the SEL. The SV lamp is on. To increase the exhaust volume adjust the static pressure set point up with the  $\wedge$  button. To decrease the exhaust volume, adjust the static pressure set point down with the  $\vee$  button. The rule of them is approximately 0.5 increase or decrease to change the exhaust volume by 5%. This is only a rule of thumb. After the adjustment the exhaust volume must be measured again. After three seconds the DMP will operate at the new SV setting.

# ODOR SPRAY SYSTEM

## ***Operating and Maintenance***

The Spring Air Systems Inc. odor spray unit has a one-year warranty from startup. The two timers, cycle timer B01, and spray timer B02, are factory set (5 minute cycle and 2 second spray) and then adjusted during startup to the odor reducing intensity required for the application. The B01 cycle timer is generally set between 5 to 10 minutes. The B02 spray timer is generally set between 2 to 60 seconds.

### **How does it Work?**

The odor spray setting is a qualitative measurement. The spray timers are field set to provide adequate odor reduction for the installation. This is completely subject to what a particular person feel is an acceptable discharge odor.

During the spray timer activation the combination air compressor and air-atomizing nozzle injects a volume of odor solution into the exhaust discharge. This solution is carried along the discharge duct and vented to atmosphere. The spray solution chemically activates with the kitchen exhaust air to reduce the kitchen exhaust odors. As the solution is carried down the duct some adheres to the duct walls. We will call this the spray residue. During the cycle time when the spray is not activated this spray residue continues the odor reducing process as the exhaust air passes. Therefore installation with longer discharge ducts can normally use a longer cycle time because there will be more spray residue. A shorter run of discharge duct usually results in shorter cycle time.

- A. When adjusting the timers the object is to use as little spray solution as possible to provide adequate odor reduction:
  1. First adjust the spray cycle, B01 timer.
  2. Reduce this setting by  $\frac{1}{2}$  of the original cycle setting and check the operation. If  $\frac{1}{2}$  proves adequate, increase the cycle back to  $\frac{3}{4}$  of the original cycle setting. If this is adequate increase to  $\frac{7}{8}$  of the original setting and so forth.
  3. If reducing the setting by  $\frac{1}{2}$  is not adequate decrease the cycle to  $\frac{1}{4}$  of the original setting. If this is not adequate adjust the spray timer B02.
    - a. Increase the spray time B02 in increments of 5 seconds. After each 5 second increase evaluate the quality of the exhaust discharge air to determine if it is acceptable to the user.
    - b. When the spray timer setting equals the cycle timer settings the spray will be continuous. The maximum setting of B02 should not exceed the cycle timer B01.

The odor spray bottle must be changed regularly depending on the length of time set on timers B01 and B02. The odor spray line from the spray bottle to the spray nozzle must be cleaned every 6 months in a water and detergent mixture. The compressed air gauge should read between 10 and 15 psi. When the air gauge is reading below 10 psi clean out the compressed air line. If the pressure is still low proceed to the next step compressor maintenance.

### **When there is odor in adjoining floors or office spaces**

A kitchen located in the interior of an office building must be very negative to keep the kitchen odor within the kitchen. We recommend the kitchen be a minimum 20% negative. The fresh air supply is 80% of the total exhaust air from the kitchen space. When there is odor in adjoining spaces check the following.

1. The kitchen is not negative enough to keep the smell of the kitchen in the kitchen. If this is the case the odor is usually present all the time, even when there is no cooking. Reduce the amount of fresh air to the kitchen by adjusting the supply fan volume.
2. The kitchen may be connected to the same building A/C unit as the rest of the floor. If this is the case the return air grilles in the kitchen draws the kitchen odor to the main A/C unit and disperses the odor throughout the floor. The main A/C return must be blocked from the kitchen and put on a separate A/C unit.
3. The floor above the kitchen have odor. There are three possibilities.
  - a. The exhaust shaft is not sealed and the kitchen exhaust is leaking out onto the floors above the kitchen. Either adjust the amount of odor spray per section "A" above or install an exhaust fan on the roof to draw the kitchen exhaust to the roof and maintain a negative pressure in the discharge duct.
  - b. The odor may escape when the kitchen is not operating during the night. After the kitchen is shut off kitchen odor may migrate up the exhaust duct and leak out into the adjoining

floors. This can be solved by operating the kitchen exhaust for a couple hours after the cooking has stopped for the day and starting the kitchen exhaust fan an hour before cooking starts in the morning.

### Odor Spray Compressor Maintenance

Do not, at any time lubricate any of the parts with oil, grease, or petroleum products nor clean with acids, caustics or chlorinated solvents. Be very careful to keep the diaphragm from contacting any petroleum product of hydrocarbons. It can affect the service life of the pump.

To clean or replace the filters and/or rubber gasket, remove the five screws in the top of the unit. The filters and gaskets are located beneath this top plate. Remove the filters and wash then in a solvent and/or blow off with air and replace. The gasket may be cleaned with water. Replace the filters in proper position and replace the gasket. Note that the gasket and top plate will fit in one position only.

To replace the diaphragm, remove the socket cap screws from the head of the pump. The diaphragm is held in place by two Philip head screws. Remove screws, retainer plate, and diaphragm. The diaphragm will fit in any position on the connecting rod. Replace the plate and the two Phillips head screws. Torque to 30 inch-pounds on DOA and DAA.

**Caution:** Do not raise any burrs or nicks on the heads of these screws. These burrs could cause damage to the inlet valve.

For replacing the inlet and outlet valve, remove the slotted machine screw that holds each valve in place. The stainless steel inlet and outlet valves are interchangeable. Clean them with water. When replacing the outlet valve, place the new valve in location and note there is a retaining bar near the machine screw hole. This retaining bar holds the valve in position. When replacing the inlet valve, note that the valve holder is marked with an X in one corner. This X should be in the lower right hand corner toward the inlet of the air chamber. Replace the head and tighten the socket head screws to 90-100 inch-pounds or torque on DOA and DAA.

**WARNING -**  
*The motor is thermally protected and can automatically restart when the protector resets. ALWAYS disconnect KES fan power source before servicing.*

Do not attempt to replace the connecting rod or motor bearings. If after cleaning the unit and/or installing a new service kit, the unit still does not operate properly, contact your representative, the factory, or return the pump to one of our authorized Service Centers.

*IF YOUR PUMP IS EQUIPPED WITH PLASTIC PLUGS IN THE EXHAUST AND/OR INTAKE POTS, REMOVE BEFORE STARTING THE UNIT*

### Wiring Information

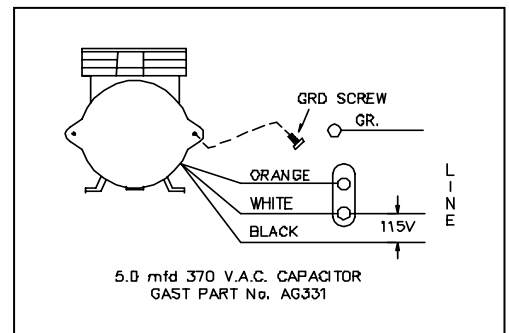
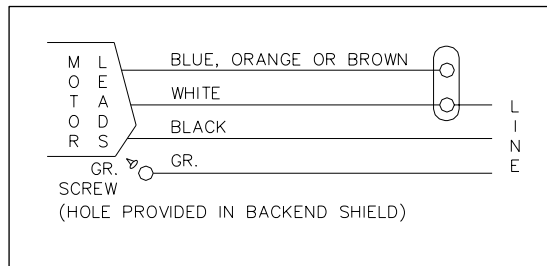

For any permanent split capacitor motor, which has four (4) leads is as follows:  
 Brown leads to capacitor. Black-leads to Power Source.

For any permanent split capacitor for DOA & DAA motor, which has three (3) leads is as follows:

### IMPORTANT NOTICE:

**DO NOT AT ANY TIME ATTEMPT TO REMOVE THE CONNECTING ROD OR COMPLETELY DISASSEMBLE THE PUMP. IF IT DOES NOT GIVE YOU THE PROPER SERVICE EVEN AFTER INSTALLING A NEW SERVICE KIT, PLEASE RETURN IT TO ONE OF THE AUTHORIZED SERVICE CENTERS**

## WHERE TO PURCHASE FILTERS:

### Spring Air Systems Inc.

1388 Cornwall Rd., Oakville Ont., L6J 7W5  
(905) 338-2999

### Airguard Industries

125 Buttermill Rd., Concord, Ontario, L4K 3X5  
905-669-9876

### Airguard Corp.

4806 Strong Rd., Crystal Lake, IL, 60014  
888-324-5665

### Camfil Farr Filters

67 Steelecase Rd. W., Markham Ont., L3R 2M4  
(905) 415-3030

### Camfil Farr

2201 Park Place, El Segundo, CA, 90245  
310-727-6300

### RECOMMENDATION

*TO ENSURE TROUBLE FREE OPERATION FOR YOUR KITCHEN EXHAUST SYSTEM A PROPER PREVENTATIVE MAINTENANCE PROGRAM IS A NECESSITY.*

*SPRING AIR SYSTEMS RECOMMENDS THAT A YEARLY SERVICE CONTRACT BE SET UP WITH A REPUTABLE SERVICE ORGANIZATION. THIS WILL REDUCE UNEXPECTED DOWN TIME TO A MINIMUM.*

## REPLACEMENT FILTER EQUIVALENTS

### PREFILTERS: MERV7 (30% ASHRAE 52-76) - ULC Class II

Airguard: 24" x 24" x 2" - DP40 Class II  
12" x 24" x 2" - DP40 Class II

#### American Air Filter:

24" x 24" x 2" - AM-AIR Class II  
12" x 24" x 2" - AM-AIR Class II

#### Farr Filters:

24" x 24" x 2" - 30% ASHRAE 52-76 Class II  
12" x 24" x 2" - 30% ASHRAE 52-76 Class II

### BAG FILTERS: MERV13 (90 - 95% ASHRAE 52 - 76) - ULC Class II

Airguard: 24" x 24" x 22" - V9-4M Class II  
12" x 24" x 22" - V9-4M Class II

#### American Air Filter:

24" x 24" x 21" - DRI-PAK - Class II  
12" x 24" x 21" - DRI-PAK - Class II

#### Farr Filters:

24" x 24" x 22" - 90% ASHRAE 52-76 Class II  
12" x 24" x 22" - 90% ASHRAE 52-76 Class II

### BOX FILTERS: MERV16 (95% DOP/99% ASHRAE 52-76) ULC Class II

Airguard: 24" x 24" x 12" - VMB- 904 Class II  
12" x 24" x 12" - VMB-904 Class II

#### American Air Filter:

24" x 24" x 12" - BIOCELL Class II  
12" x 24" x 12" - BIOCELL Class II

#### Farr Filter:

24" x 24" x 12" - 6 pocket - 95% DOP Class II  
12" x 24" x 12" - 6 pocket - 95% DOP Class II

### ODOR MEDIA: 1/8" Activated alumina pellets impregnated with potassium permanganate.

Airguard: Barneby-Cheney CP-2

#### American Air Filter:

Permasorb

#### Farr Filters:

Unisorb.

**Odor Spray:** Spring Fresh, Spring Air Systems

## WHEN TO CHANGE THE KES FILTERS

The Prefilter, Bag filter and Box filter must be changed on a regular basis to maintain the high grease extraction efficiency required by the UL/ULC listing. Once a filter clogged light comes on the filter has reached its grease holding capacity. Further use will restrict exhaust air flow causing hood smoke capture problems and/or cause the clogged filter to blow out into the next filter or the exhaust fan. Therefore the three particulate filters must be changed before the Filter Clogged lights activate and shut the unit down under normal kitchen operation. This will provide simple uninterrupted operation for your commercial kitchen operation.

### Determine the Filter Change Schedule

When the KES unit is turned over to you by the installing contractor immediately change the Prefilters. The Prefilters will probably be full of construction debris and this debris will effect the initial operation of the unit.

#### **PREFILTERS**

1. Enter the startup date on the attached FILTER FREQUENCY CHART. This is the date the Prefilters were changed as well.
2. Run the unit until the Prefilter Clogged lights turns on. When the light comes on the unit will shut down. Immediately turn the Override switch clockwise and put the unit into override. The unit will come back on. Change the prefilters at the end of the shift or the next day before cooking. Write the date that the Prefilters were changed on the FILTER REQUENCY CHART under Filter Change No. 1/Actual.
3. Determine the number of days between the Startup date and the Prefilter Change No. Actual date. Subtract two days from this number. Add the this number of days to the last actual prefilter change and enter this new prefilter schedule date in the schedule under Filter Change No. 2/Schedule. Change the Prefilters on this new date. If the Filter light activates before this new date reduce the number of days to the next scheduled change by one day.

#### **BAG FILTERS**

1. Run the unit until the Bag Filter Clogged lights turns on. When the light comes on the unit will shut down. Immediately turn the Override switch clockwise and put the unit into override. The unit will come back on. Change the Bag filters at the end of the shift or the next day before cooking. Write the date that the Bag filters were changed on the FILTER REQUENCY CHART under Filter Change No. 1/Actual.
2. Determine the number of days between the Startup date and the Bag filter Change No. Actual date. Subtract two days from this number. Add the this number of days to the last actual bag filter change and enter this new bag filter schedule date in the schedule under Filter Change No. 2/Schedule. Change the bag filters on this new date. If the Filter light activates before this new date reduce the number of days to the next scheduled change by one day.

#### **BOX FILTERS**

1. Run the unit until the Box Filter Clogged lights turns on. When the light comes on the unit will shut down. Immediately turn the Override switch clockwise and put the unit into override. The unit will come back on. Change the Box filters at the end of the shift or the next day before cooking. Write the date that the Box filters were changed on the FILTER REQUENCY CHART under Filter Change No. 1/Actual.
2. Determine the number of days between the Startup date and the Box filter Change No. Actual date. Subtract two days from this number. Add the this number of days to the last actual box filter change and enter this new box filter schedule date in the schedule under Filter Change No. 2/Schedule. Change the box filters on this new date. If the Filter light activates before this new date reduce the number of days to the next scheduled change by one day.



By following the above procedure you will maximize your filter life. Changing the prefilter prior to clogging improves the bag filter life and changing the bag filter prior to clogging improves the box filter life.

**LACK OF EXHAUST VOLUME PRIOR TO SCHEDULED FILTER CHANGE  
(IF YOU HAVE A MXFLOW OPTION ON YOUR KESF SKIP THIS SECTION)**

When all the filters are clean the exhaust volume is at the maximum. Each of the three filters captures various size grease particulate. The Prefilter capturing the very largest and the Box filter the very smallest. In very heavy applications with large quantities of both micron and submicron particles the exhaust air volume will reduce as the filters clog. If the loading is too heavy the FILTER OUT light will activate. This means that either someone has removed a filter or the exhaust air volume has reduced to a dangerous level. Immediately change the Prefilter. If this does not clear the FILTER REMOVED annunciation change the BAG Filter. Reschedule the next filter changed based on this new period of time.

Similarly should you experience lack of smoke capture during operation of your hood system prior to a scheduled filter change immediately change the Prefilter. If this does not clear the problem change the BAG Filter. If this does not clear the problem put the old Prefilter and Bag Filters in the unit replace the Box Filter. If this does not clear the problem replace the Prefilter and Bag Filters. Reschedule the next filter changed based on this new period of time.

FILTER FREQUENCY CHART						
Startup date/First Prefilter change						
Change No.	Prefilter		Bag Filter		Box Filter	
	Schedule	Actual	Schedule	Actual	Schedule	Actual
1						
2						
3						
4						
5						
6						
7						
8						
9						
10						
11						
12						
13						
14						
15						
16						
17						
18						
19						
20						
21						
22						
23						
24						

## **TROUBLE SHOOTING**

### ***I. Exhaust fan does not run.***

Reset the system once. Press the reset button in the LV10 J-Box or turn the fan selector switch to “OFF” and “ON”. Observe the sequence that follows.

#### **1.The fan does not start and there is no indication on remote panel.**

- a)Check power from the breaker to the RPD-KW panel.
- b)Check the three wiring connection from the wash panel to the RPD-KW panel.

#### **2.The fan does not start but the green normal pilot energizes for 30 seconds goes out and “Filter removed” pilot energizes.**

- a)Check wiring between KES filter box LV10 J-box terminals 5 & 4 and the KESF fan motor starter.
- b)Check wiring between the RPD-KD or RPD-KW remote and the KES-ISH LV10 J-Box
- c)Reset the exhaust fan overload in the exhaust fan motor starter on the KESF fan section.
- d)Check three phase power to the KESF fan section disconnect.
- e)Check if exhaust duct access door is open between the KES filter section and hood.
- f)Check that all filters on in place.
- g)Check if the prefilter or box filter access door on the KES unit is open
- h)Check the actual operating pressure (Ax) and the FILTER OUT pressure setting for each of the pressure transducers connected to the LV10 PLC. Set Appendix for adjustment details. Adjust the pressure setting or replace the transducer.
- i)If all the filters are in place check if pressure tips on the end of the pressure switch manifolds are plugged. There is a pressure tip in front and behind each filter.
- j)Measure Exhaust air volume. If low increase fan RPM to within FLA of fan motor
- k)Check KESF exhaust fan motor starter coil. Replace or repair.
- l)Check KESF fan belts if loose or broken.
- m)Check KESF exhaust fan motor. Replace or repair.
- n)MXFLOW units: check start/stop relay in the LV10 panel for correct operation. Coil should pull in when RPD-KD selector switch is powered. Check if DMP digital display is on. If there is not display there is no power on terminals 5&4 from the remote panel.

#### **3.The exhaust fan runs for 30 seconds then shuts off and one of the FilterClogged pilots energizes.**

- a.Check the actual operating pressure (Ax) and the FILTER CLOGGED Setting on each the pressure transducers connected to the LV10 PLC. Adjust the setting if the filters are not actually clogged.
- b.Check the wiring between the RPD-KD or RPD-KW panel and the LV10 J-Box.

## **II. Low Exhaust Air**

### **1.Exhaust fan is running but exhaust air is low.**

- a)Check if fan belts are slipping. Tighten if necessary.
- b)Check if fusible link fire damper has closed in the KES filter section. Replace fusible link.
- c)Check if filters are dirty but have not activated the "Filter Clogged" pilot. Replace dirty filters.
- d)Check for correct fan rotation. On MXFLOW units to correct fan rotation switch two of the high voltage wires on terminals V/T1, U/T2 or W/T3 on the drive or switch two wires at the motor disconnect.

## **III. Filter Clogged Pilot On.**

- 1.Filter clogged pilot indicates which filter section has plugged. Replace filter and reset system.
2. If the filter clogged activates earlier then the normal established check the actual operating pressure (Ax) and the FILTER CLOG pressure setting for each of the pressure transducers connected to the LV10 PLC. Set Appendix for adjustment details. Adjust the pressure setting.
3. If adjusting the pressure switches is not effective and the amount/usage of the kitchen has not increased check the recommended filter clogged limits from the filter manufacturer.

## **IV. Filter Removed Pilot On.**

- 1.A filter has been removed or access door left open. Replace if necessary.

## **V. Fire Pilot On.**

- 1.The fire stat in the KES filter section exhaust outlet has activated and shut the KES system down. If a fire is not present check calibration of firestat TH1. Firestat should be set at 160F.

If operation problems persist check the individual the connection between the RPD-KD or RPD-KW panel and the LV10 J-Box. If problems still exist contact an authorized SPRING AIR SYSTEMS service technician.

## **KES MAINTENANCE SCHEDULE**

### ***Every two weeks: See “When to Change Filter Section”***

1. Inspect the prefilters. Replace if necessary. It is important to maintain clean prefilters. Replacing the inexpensive prefilters often extends the life of the bag and box filters and reduces unnecessary down time due to clogged filter shutdowns. *The RPD or RPW annunciation panel will indicate separately when the “prefilter”, “bag” and “box” filters are clogged. When this occurs the unit shuts down. Rotate the override switch to energize the system for about 4 hours. This provides time to change the filters after the day of cooking. This is a final dirty filter warning. The filter life of all the filters is constant for each operation. Once the approximate filter life for your application is determined we recommend that a regular filter change schedule be set up before the filter out switches activate.*

### ***Every Month: “When to Change Filter Section”***

1. Complete the two-week list.
2. Inspect the exhaust fan belt for correct tension and wear. All belts usually require adjustment at this time. Failure to tighten may result in the belt falling off and no airflow.
3. Inspect the bag filters (2nd stage filtration). Replace if necessary. The life of the bag filter depends on the type of cooking equipment and exhaust hood system. For heavy cooking applications the bag filters may require replacement every month.
4. **(Odor Spray Option)** Inspect the odor spray bottle. Refill if necessary. *At startup the odor spray is adjusted to the desired level. The amount of odor spray used varies with this initial setting. It is important to inspect the level in the bottle every two weeks until the normal rate of use is determined.*

### ***Every Three Months: “When to Change Filter Section”***

1. Complete the two-week and monthly checklist.
2. Inspect the exhaust fan belt for correct tension and wear. Adjust if necessary.
3. Inspect the box filters (3rd stage filtration). Replace if necessary. Once again the life of the box filter depends on the type of cooking equipment and exhaust hood system. The box filter may provide one year of service on most applications with high efficiency water wash ventilators.
4. Inspect all electrical connections. Tighten if necessary.
5. Test the filter-removed circuit. Open the prefilter access door while the KES unit is in operation. The unit should shut down and indicate a filter-removed condition.

### ***Every Six Months “When to Change Filter Section”***

1. Complete the two-week, monthly and three month check list.
2. Open the fan wheel access door or hatch on the KES fan section. Inspect the fan wheel for grease build up. Clean as required.
3. Inspect the exhaust inlet fire damper and fusible link. Replace link annually.
4. Check the motor and fan bearings for noise or overheating.
5. **(Odor Pellet Option)** Inspect the condition of odor media.
6. *The odor media pellets can be checked for remaining life by sending a sample to an accredited test laboratory. Most major filter suppliers have access to such service. Replace media if required. To replace the media remove the cells from*

*the KES unit. Open the side panel on each odor cell and pour out the used media. Refill the cells with new media. Shake cells while filling to allow pellets to settle evenly in the cell. **Note:** Do not allow odor media to come in contact with water, as this will immediately render the pellets useless.*

### **Fan Bearings**

1. STY and FYC bearings are factory pre-lubricated lifetime sealed and require no further lubrication.
2. SY and FY bearings are pre-lubricated and equipped with pressure grease fittings for re-greasing.
3. Under normal service conditions grease after six months of operation.

### **Motor Bearings:**

1. All motors leave the factory with bearings custom greased for many years of service under most conditions.
2. Re-greasing of motors depends on the application and is best left to trained service technicians.
3. Periodically check if motor is running hotter than normal.

### **Centrifugal Exhaust Fan:**

1. Make sure the wheel rotates freely before startup.
2. Inspect and clean the wheel periodically.
3. If dirt is allowed to build up the wheel could become out of balance and cause premature bearing wear.
4. A noisy fan is a typical sign of a fan out of balance.

### **V-Belt Drives:**

1. ALWAYS KEEP SPARE SET OF BELTS. Periodically check the belt tension and adjust if necessary.
2. Some slack should be left in the belt, typically 1/4" per foot of belt from the fan to the motor sheave.
3. Always replace the complete set of belts to ensure even tension and wear. When replacing belts loosen the motor mounts.
4. Do not force belts over sheaves.

### **RECOMMENDATION**

TO ENSURE TROUBLE FREE OPERATION FOR YOUR KITCHEN EXHAUST SYSTEM A PROPER PREVENTATIVE MAINTENANCE PROGRAM IS NECESSARY. SPRING AIR RECOMMENDS THAT A YEARLY SERVICE CONTRACT BE SET UP WITH A REPUTABLE SERVICE ORGANIZATION. THIS WILL REDUCE UNEXPECTED DOWN TIME TO A MINIMUM.

# APPENDIX

## A. MXFLOW ONLY:

### SETTING THE DMP (PXR) Controller for Pressure Transducer

	<b>Set Point (SV parameter) - Setting the set point</b>
SV=total static pressure	Press SEL once. Use V and Λ to adjust the project set point. Press SEL. The factory setting is the total static pressure indicated on the KESF unit drawings" W.C. (Total static pressure)

### PXR3 Micro-controller: Factory setup

Power the MXFLOW panel and proceed to input the following setting.

	<b>2<sup>nd</sup> Block Parameters</b>
	Press SEL and hold for about 3 seconds until P appears on the display. Release SEL.
P=17.3	Press SEL again to set the Proportional Band. Use the Λ to increase parameter set value and V to decrease parameter set value. Set P = 17.3 and then press SEL.
I=12	Press V to next parameter, integral time, I. Press SEL and set value to 12. Press SEL
d=6.6	Press V to next parameter, derivative action time, d. Press SEL and set value to 6.6. Press SEL.
hys=6.6	Press V to next parameter, hysteresis, hys. Press SEL and set value to 6.6. Press SEL
CTrL=PID	Press V three times to next parameter, Control algorithm, CTrL. Press SEL and check that the setting is PID. If is not us the V and Λ to set to PID and then press SEL.
P-n2=16	Press V three times to next parameter, input type code, P-n2. Press SEL and adjust setting to 16. Press SEL.
P-SL=0	Press V to next parameter, Lower limit of input range, P-SL. Press SEL and adjust setting to 0. Press SEL.
P-SU=10	Press V to next parameter, Upper limit of input range, P-SU. Press SEL and adjust setting to 10. Press SEL.
	Press SEL and hold for about 2 seconds to return to set point.



	<b>3<sup>rd</sup> Block Parameters</b>
	Press SEL and hold for about 5 seconds until P-n1 appears on the display. Release SEL.
P-n1=1	Press SEL again to set the Control Action, P-n1. Use the Λ and V to adjust the value to 3. Press SEL.
SV-L=0	Press V to next parameter, Lower limit of SV, SV-L. Press SEL and adjust setting to 0. Press SEL.
SV-H=8	Press V to next parameter, Upper limit of SV, SV-H. Press SEL and adjust setting to 8. Press SEL.
	Press SEL and hold for about 2 seconds to return to set point.

	<b>1st Block Parameters</b>
	Press SEL and hold for about 1 second until STbY appears on the display. (or LACH)
AT=1	<b>AUTOTUNING</b> Press V until AT appears on display. Press SEL and set the Auto-tuning to 1. using V and Λ. Press SEL.
StbY	Set to off
Prog	Set to off

After re-programming any value **Autotune** the controller again.

## [8] Sensor fault operation

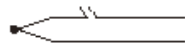
### • Thermocouple

Condition		Display	Control output
Break		<b>UUUUU</b>	ON or more than 20mA OFF or less than 4mA (Note)
Short circuit		short-circuit point Temperature display	Input is controlled as short-circuit point temperature. (Note)

### • 4-20mA DC

Over-range	<b>UUUUU</b>	OFF or less than 4mA (Note)
Under-range	<b>LLLLL</b>	ON or more than 20mA



## B. MXFLOW ONLY:

### FACTORY DRIVE TERMINAL SCHEMATIC

Wiring Diagram for Factory Settings

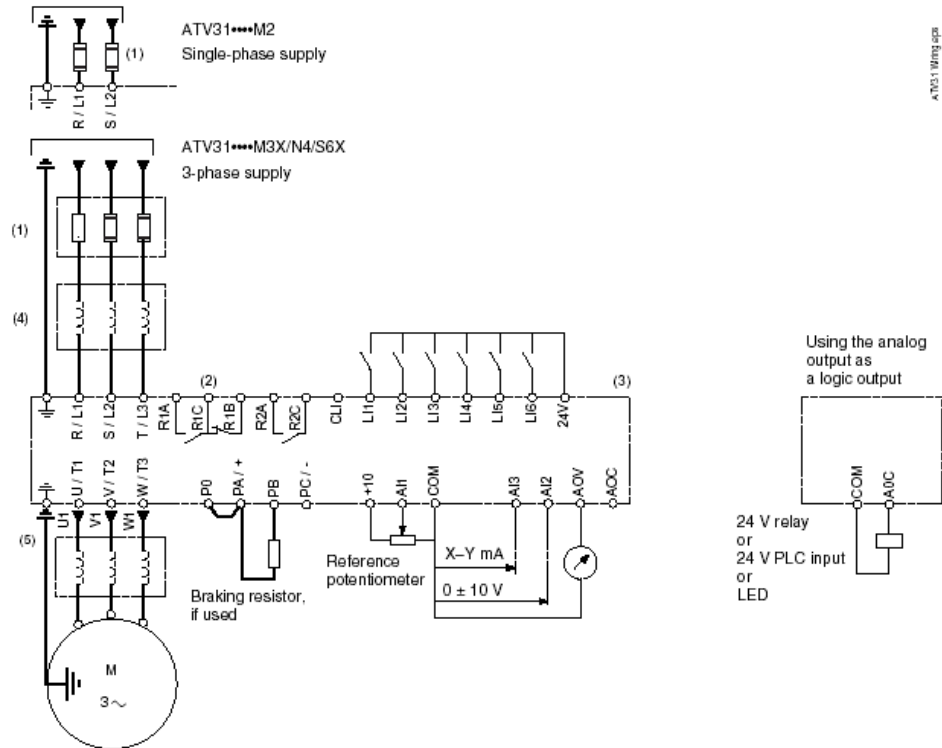

*NOTE: The line supply terminals are shown at the top and the motor terminals are shown at the bottom. Connect the power terminals before connecting the control terminals. Install surge suppressors on all inductive circuits located near the drive controller or coupled to the same circuit.*

- (1) Refer to the drive controller nameplate or to the tables on pages 34–35 for recommended fuses. Fast acting or time delay Class J fuses can be used.
- (2) Fault relay contacts for remote indication of drive controller status.
- (3) Internal +24 V. If an external source is used (30 V max.), connect the 0 V terminal of the source to the 0 V (COM) terminal, and do not use the +24 V terminal on the drive controller for any purpose.
- (4) Line reactor, if used. All 575 V installations must include a line reactor. See page 21.
- (5) Installation of a load filter is recommended for all 575 V applications. See page 22.

ATV31 Wiring.spc

## LOGIC INPUT SWITCH

The logic input switch assigns the logic input common link to 0 V (Source logic), 24 V (Sink logic), or floating.

*NOTE: When the logic input is configured for Sink logic, grounding the input signals can result in unintended activation of drive controller functions.*

**⚠ DANGER**

**UNINTENDED EQUIPMENT OPERATION**

- Protect the signal conductors against damage that could result in unintentional conductor grounding.
- Follow NFPA 79 and EN 60204 guidelines for proper control circuit grounding practices.

**Failure to follow these instructions can result in death, serious injury, or equipment damage.**

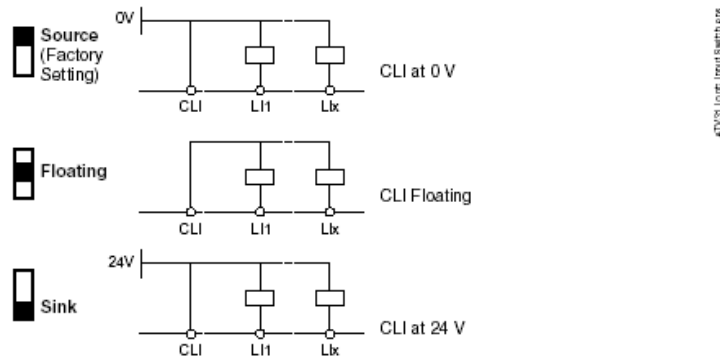

## DRIVE TECHNICAL SPECIFICATIONS FOR LOCATING DRIVE PANELS

**Table 2: Environment**

Degree of Protection	<ul style="list-style-type: none"> <li>• IP20 without protective vent cover, NEMA 1, UL open type.</li> <li>• IP21 on wiring terminals</li> <li>• IP31 and IP41 all other areas</li> <li>• UL Type 1 without removal of the protective vent cover from the top of the controller and with the addition of the Conduit Entry Kit (see page 14).</li> </ul>
Resistance to vibrations	Conforming to IEC/EN 60068-2-6: 1.5 mm peak to peak from 3 to 13 Hz, 1 gn from 13 to 150 Hz
Resistance to shocks	15 gn for 11 ms conforming to IEC/EN 60068-2-27
Pollution degree	Pollution degree 2 according to UL 840. Protect the drive controller against dust, corrosive gas, and falling liquid.
Maximum relative humidity	96% maximum, non-condensing and without dripping (provide heating system if there is condensation) Conforms to IEC 60068-2-3
Maximum ambient temperature	Storage: -13 to +158 °F (-25 to +70 °C) Operation: +14 to +122 °F (-10 to +50 °C) without vent cover removed and without derating +14 to +140 °F (-10 to +60 °C) with vent cover removed and with derating. Refer to derating curves on page 15.
Altitude	Up to 3,300 ft (1,000 m) without derating; derate by 1% for each additional 330 ft (100 m)

## C. HAZARDOUS WARNING

**⚠ DANGER**

**HAZARDOUS VOLTAGE**

- Read and understand this manual before installing or operating the Altivar 31 drive controller. Installation, adjustment, repair, and maintenance must be performed by qualified personnel.
- For more information on Altivar 31 drive controllers, see the *Altivar 31 Start-Up Guide*, VVDED303043US, and the *Altivar 31 Programming Manual*, VVDED303042US. Both manuals are shipped with the drive controller. They are also available from [www.us.SquareD.com](http://www.us.SquareD.com) or from your Schneider Electric representative.
- The user is responsible for conforming to all applicable code requirements with respect to grounding all equipment.
- Many parts in this drive controller, including printed wiring boards, operate at line voltage. **DO NOT TOUCH.** Use only electrically insulated tools.
- **DO NOT** touch unshielded components or terminal strip screw connections with voltage present.
- **DO NOT** short across terminals PA and PC or across the DC bus capacitors.
- Install and close all covers before applying power or starting and stopping the drive controller.
- Before servicing the drive controller:
  - Disconnect all power.
  - Place a "DO NOT TURN ON" label on the drive controller disconnect.
  - Lock the disconnect in the open position.
- Disconnect all power including external control power that may be present before servicing the drive controller. **WAIT 3 MINUTES** for the DC bus capacitors to discharge. Then follow the DC bus voltage measurement procedure on page 20 to verify that the DC voltage is less than 45 Vdc. The drive controller LEDs are not accurate indicators of the absence of DC bus voltage.

**Electric shock will result in death or serious injury.**

## D. MXFLOW ONLY: GOOD WIRING PRACTICE

Good wiring practice requires the separation of control circuit wiring from all power (line) wiring. In addition, power wiring to the motor must have the maximum possible separation from all other power wiring, whether from the same drive controller or other drive controllers; **do not run in the same conduit**. This separation reduces the possibility of coupling electrical transients from power circuits into control circuits or from motor power wiring into other power circuits.

### CAUTION

#### IMPROPER WIRING PRACTICES

- Follow the wiring practices described in this document in addition to those already required by the National Electrical Code and local electrical codes.
- The drive controller will be damaged if input line voltage is applied to the output terminals (U, V, W).
- Check the power connections before energizing the drive controller.
- If replacing another drive controller, verify that all wiring connections to the ATV31 drive controller comply with all wiring instructions in this manual.

**Failure to follow this instruction can result in injury or equipment damage.**

Follow the practices below when wiring ATV31 drive controllers:

- Verify that the voltage and frequency of the input supply line and the voltage, frequency, and current of the motor match the rating on the drive controller nameplate.
- Use metallic conduit for all drive controller wiring. Do not run control and power wiring in the same conduit.
- Separate the metallic conduits carrying power wiring from those carrying control wiring by at least 76 mm (3 in.).
  
- Separate the non-metallic conduits or cable trays used to carry power wiring from the metallic conduit carrying control wiring by at least 305 mm (12 in.).
- Whenever power and control wiring cross, the metallic conduits and non-metallic conduits or trays must cross at right angles.
- Equip all inductive circuits near the drive controller (such as relays, contactors, and solenoid valves) with noise suppressors, or connect them to a separate circuit.

## E. MXFLOW ONLY: GROUNDING

Ground the drive controller according to the National Electrical Code and all local codes to ensure safe, dependable operation. To ground the drive controller:

- Connect a copper wire from the equipment ground lug or terminal to the power system ground conductor. Size the wire according to the drive controller rating and national and local codes.
- Verify that resistance to ground is one ohm or less. Improper grounding causes intermittent and unreliable operation.

**⚠ DANGER**

**HAZARDOUS VOLTAGE**

Ground equipment using the provided ground connecting point as shown in the figure below. The drive controller panel must be properly grounded before power is applied.

**Electric shock will result in death or serious injury.**



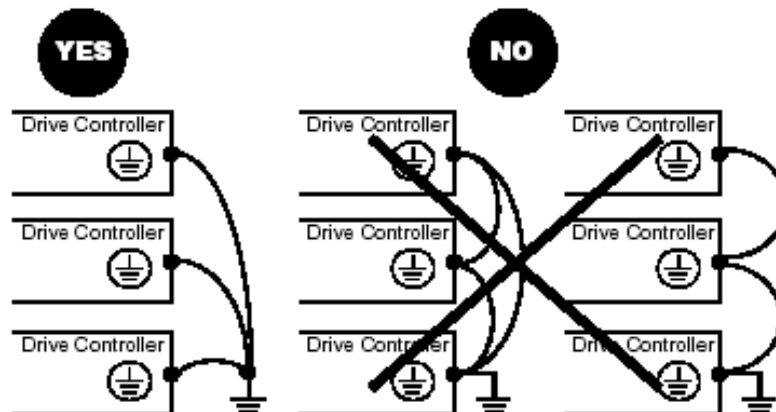

Ground multiple drive controllers as shown in the figure below. Do not loop the ground cables or connect them in series.

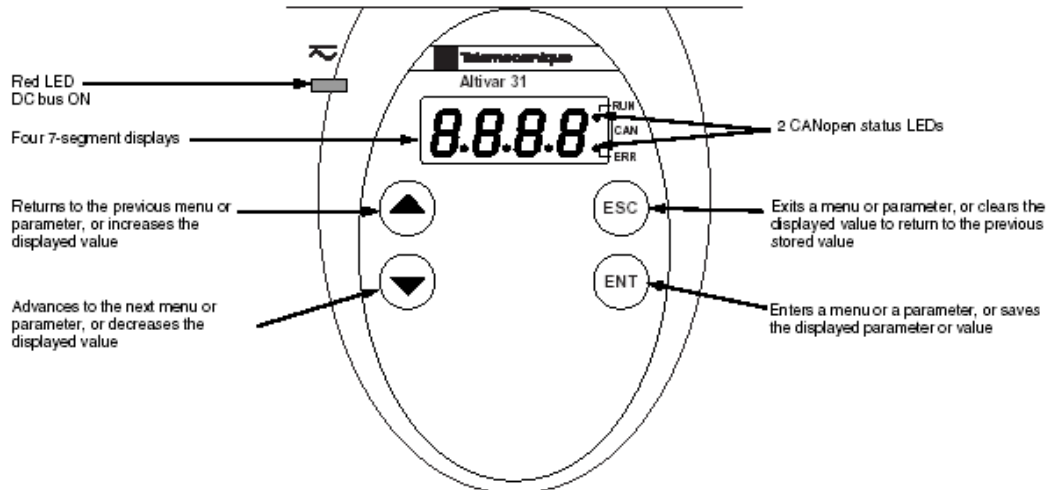

## F. MXFLOW ONLY: STARTING THE DRIVE

### ATV31\*\*\*\*\* Controllers



- Press and hold down (longer than 2 seconds) the  or  keys to scroll through the data quickly.
- Pressing  or  does not store the selection.
- To store the selection, press the  key. The display flashes when a value is stored.

A normal display with no fault present and no run command shows:

- The value of one of the display parameters (see page 80). The default display is motor frequency, for example 43.0. In current limiting mode, the display flashes.
  - init: Initialization sequence
  - rdY: Drive ready
  - dcb: DC injection braking in progress
  - nSt: Freewheel stop
  - FSt: Fast stop
  - tUn: Auto-tuning in progress
- If a fault is present, the display flashes.

## G. MXFLOW ONLY: ACCESSING THE DRIVE PROGRAM MENU

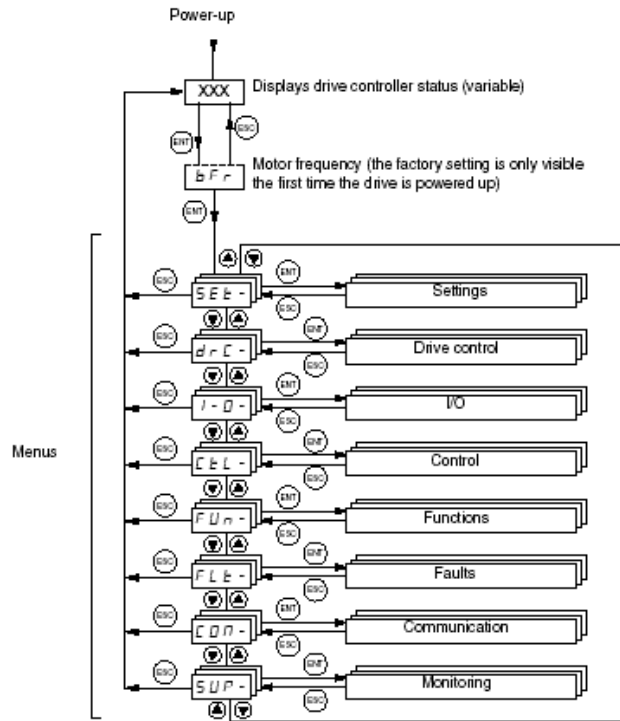

The following figure illustrates how to access parameters and assign their values. To store the parameter value, press the **ENT** key. The display flashes when a value is stored.

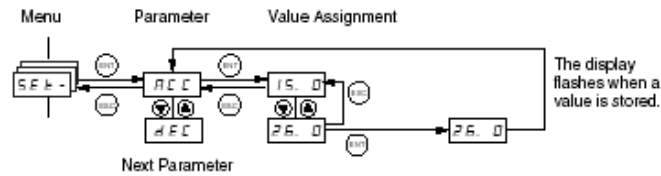

All of the menus are drop-down type menus. Once you have reached the last parameter in a list, press the **▼** key to return to the first parameter. From the first parameter in the list, press the **▲** key to jump to the last parameter.

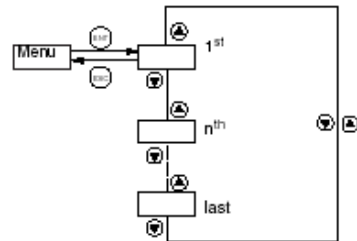

If you have modified a parameter in a menu and you return to that menu without accessing another menu in the meantime, you will be taken directly to the parameter you last modified. See the illustration below. If you have accessed another menu or have restarted the drive controller since the modification, you will be taken to the first parameter in the menu. See the illustration above.



## H. MXFLOW ONLY PROGRAMMING THE DRIVE PARAMETERS

MXFLOW Programming the variable speed Tele drive

Code	Long Label	Factory Setting	Tele Default
<b>Fast Settings</b>			
ACC	Acceleration ramp time	10.0s	3.0s
BFR	Standard motor frequency	60HZ	50HZ
DEC	Deceleration ramp time	10s	3s
ITH	Motor thermal current	Motor FLA	0.0A
**LSP	Low Speed	48HZ	0.0HZ
<b>Motor Control</b>			
NSP	Nominal Motor Speed	1725 rpm of motor	1715tr/min
TUN	Automatic Tuning	Autotune on Power up	Not Assigned
<b>Terminal Configuration</b>			
AOIT	Configuration of AOI	4-20mA	0-20mA
DO	AOC/AOV Assignment	Motor Frequency	Not Assigned
R1	Relay R1	Drive Running	Drive Fault
RRS	Reverse	Not Assigned	Logic Input LI2
<b>Control Command</b>			
FR1	Configuration reference 1	Analog Input AI3	Analog input AI1
LAC	Function Access Level	Advance Function & Mixed ctrl	Access to Std. Function
<b>Input Summary</b>			
AI1A	Configuration of AI1	CH. In forced local Mode	Configuration ref. 1
AI2A	Configuration of AI2	Not Assigned	Summing Input 2
AI3A	Configuration of AI3	Configuration ref. 1	Not Assigned
LI2A	Config. Logic Input 2	Select 2 Preset Speed	Reverse
LI3A	Config. Logic Input 3	Select 3 Preset Speed	Select 3 Preset Speed
LI4A	Config. Logic Input 4	Select 4 Reset Speed	Select 4 Preset Speed
<b>Fault Behavior</b>			
ATR	Automatic Restart	YES	NO
DRN	Derating for Undervoltage	YES	NO
<b>Application Functions</b>			
SA2	Summing Input 2	Not Assigned	Anolog Input AI2
SA3	Summing Input 3	Not Assigned	Not Assigned
SDC2	DC Current at Standstill 2	Motor Amp	0.0A
SP2	Preset Speed 2	60HZ	10HZ
SP3	Preset Speed 3	30 HX(optional)	15HZ
SP4	Preset Speed 4	50HZ (optional)	20HZ

Device Reference must be observed when programming

Parameter list based on ALTIVAR31

Motor Characteristics must be inputted (ie FLA, RPM)

Preset Speeds are adjustable.

# I. MXFLOW ONLY: TROUBLE SHOOTING AND DRIVE FAULT DISPLAY

## PRECAUTIONS

Read the following safety statements before proceeding with any maintenance or troubleshooting procedures.

 <b>DANGER</b>
<b>HAZARDOUS VOLTAGE</b>
<ul style="list-style-type: none"><li>• Disconnect all power before servicing the drive controller.</li><li>• Read and understand these procedure and the precaution on page 13 of this manual before servicing the ATV31 drive controllers.</li><li>• Installation, adjustment, and maintenance of these drive controllers must be performed by qualified personnel.</li></ul>
Failure to follow this instruction will result in death or serious injury.

## ROUTINE MAINTENANCE

Perform the following steps at regular intervals:

- Check the condition and tightness of the connections.
- Make sure that the ventilation is effective and that the temperature around the drive controller remains at an acceptable level.
- Remove dust and debris from the drive controller, if necessary.

## FAULT DISPLAY

If a problem arises during setup or operation, ensure that all ambient environment, mounting, and connection recommendations have been followed.

The first fault detected is stored and displayed, flashing, on the screen. The drive controller locks and the fault relay (RA-RC) contact opens, if it has been configured for this function.

## Drive Controller Does Not Start, No Fault Displayed

If the drive controller will not start and there is no display indication, consider the following:

1. Check the power supply to the drive controller.
2. The assignment of the fast stop or freewheel stop functions prevents the drive controller from starting if the corresponding logic inputs are not powered up. In this case, the drive controller displays nSt in freewheel stop mode and FSt in fast mode. This is normal, since these functions are active at zero speed so that the drive controller will stop safely if there is a wire break.
3. Ensure that the run command inputs have been actuated in accordance with the chosen control mode (ICC parameter in the I-O- menu. See page 29).
4. If an input is assigned to the limit switch function and this input is at state 0, the drive controller can only be started by sending a command for the opposite direction (see page 72).
5. If the reference channel (page 37) or the control channel (page 38) is assigned to Modbus or CANopen, the drive controller displays nSt on power up and remains stopped until the communication bus sends a command.

## TROUBLESHOOTING

### Fault Display

If a problem occurs during setup or operation, ensure that all ambient environment, mounting, and connection recommendations have been followed.

The first fault detected is stored and displayed, flashing, on the screen. The drive controller locks and the fault relay (R1A-R1C or R2A-R2C) contact opens.

### Drive Controller Does Not Start, No Display

If the drive controller will not start and there is no display indication, check the power supply to the drive controller. Refer to the *ATV31 Programming Manual* for more troubleshooting information.

### Faults Which Cannot be Automatically Reset

Faults which cannot be automatically reset are listed in the table beginning on page 44. To clear these faults:

1. Remove power from the drive controller.
2. Wait for the display to go off completely.
3. Determine the cause of the fault and correct it.
4. Reapply power.

CrF, SOF, tnF, bLF, and OPF can also be reset remotely via a logic input (rSF parameter in the FLT- menu, see the *ATV31 Programming Manual*).

### Faults Which Cannot be Automatically Reset

Fault	Probable Cause	Remedy
<i>b L F</i> Brake sequence	Brake release current not reached	<ul style="list-style-type: none"> <li>• Check the drive controller and motor connections.</li> <li>• Check the motor windings.</li> <li>• Check the Ibr setting in the FUn-menu. Refer to the <i>ATV31 Programming Manual</i>.</li> </ul>
<i>C r F</i> Precharge circuit fault	Precharge circuit damaged	<ul style="list-style-type: none"> <li>• Reset the drive controller.</li> <li>• Replace the drive controller.</li> </ul>
<i>I n F</i> Internal fault	<ul style="list-style-type: none"> <li>• Internal fault</li> <li>• Internal connection fault</li> </ul>	<ul style="list-style-type: none"> <li>• Remove sources of electromagnetic interference.</li> <li>• Replace the drive controller.</li> </ul>
<i>O C F</i> Overcurrent	<ul style="list-style-type: none"> <li>• Incorrect parameter settings in the SEt- and drC- menus</li> <li>• Acceleration too rapid</li> <li>• Drive controller and/or motor undersized for load</li> <li>• Mechanical blockage</li> </ul>	<ul style="list-style-type: none"> <li>• Check the SEt- and drC- parameters.</li> <li>• Ensure that the size of the motor and drive controller is sufficient for the load.</li> <li>• Clear the mechanical blockage.</li> </ul>
<i>S C F</i> Motor short circuit	<ul style="list-style-type: none"> <li>• Short circuit or grounding at the drive controller output</li> <li>• Significant ground leakage current at the drive controller output if several motors are connected in parallel</li> </ul>	<ul style="list-style-type: none"> <li>• Check the cables connecting the drive controller to the motor, and check the motor insulation.</li> <li>• Reduce the switching frequency.</li> <li>• Connect output filters in series with the motor.</li> </ul>
<i>S O F</i> Overspeed	<ul style="list-style-type: none"> <li>• Instability</li> <li>• Overhauling load</li> </ul>	<ul style="list-style-type: none"> <li>• Check the motor, gain, and stability parameters.</li> <li>• Add a braking resistor.</li> <li>• Check the size of the motor, drive controller, and load.</li> </ul>
<i>t n F</i> Auto-tuning fault	<ul style="list-style-type: none"> <li>• Motor or motor power not suitable for the drive controller</li> <li>• Motor not connected to the drive controller</li> </ul>	<ul style="list-style-type: none"> <li>• Use the L or the P ratio (see UfT on page 36).</li> <li>• Check the presence of the motor during auto-tuning.</li> <li>• If a downstream contactor is being used, close it during auto-tuning.</li> </ul>

## Faults Which Can be Reset With the Automatic Restart Function

After the cause of the fault has been removed, the following faults can be reset:

- With the automatic restart function (Atr parameter in the FLT- menu, see the *ATV31 Programming Manual*),
- Via a logic input (rSF parameter in the FLT- menu, see the *ATV31 Programming Manual*),
- By cycling power to the drive controller.

## Faults Which Can be Reset With Automatic Restart

Fault	Probable Cause	Remedy
<i>LDL</i> Serial link failure CANopen	Loss of communication between drive controller and communication device or remote keypad.	<ul style="list-style-type: none"> <li>• Check the communication bus.</li> <li>• Refer to the product-specific documentation.</li> </ul>
<i>EPF</i> External fault	User defined	User defined
<i>LLF</i> Loss of 4-20 mA follower	Loss of the 4-20 mA reference on input AI3	Check the connection on input AI3.
<i>ObF</i> Overvoltage during deceleration	<ul style="list-style-type: none"> <li>• Braking too rapidly</li> <li>• Overhauling load</li> </ul>	<ul style="list-style-type: none"> <li>• Increase the deceleration time.</li> <li>• Install a braking resistor if necessary.</li> <li>• Activate the brA function if it is compatible with the application. Refer to the <i>ATV31 Programming Manual</i>.</li> </ul>
<i>OHF</i> Drive overload	<ul style="list-style-type: none"> <li>• Drive controller or ambient temperature are too high.</li> <li>• Continuous motor current load is too high.</li> </ul>	Check the motor load, the drive controller ventilation, and the environment. Wait for the drive controller to cool before restarting.
<i>OLF</i> Motor overload	<ul style="list-style-type: none"> <li>• Thermal trip due to prolonged motor overload</li> <li>• Motor power rating too low for the application</li> </ul>	Check the lth setting (motor thermal protection, page 32), check the motor load. Allow the motor to cool before restarting.

### Faults Which Can be Reset With Automatic Restart (Continued)

Fault	Probable Cause	Remedy
<p><i>D P F</i> Motor phase failure</p>	<ul style="list-style-type: none"> <li>• Loss of phase at drive controller output</li> <li>• Downstream contactor open</li> <li>• Motor not connected</li> <li>• Instability in the motor current</li> <li>• Drive controller oversized for motor</li> </ul>	<ul style="list-style-type: none"> <li>• Check the connections from the drive controller to the motor.</li> <li>• If a downstream contactor is being used, set OPL to OAC. Refer to the <i>ATV31 Programming Manual</i>, FLT-menu.</li> <li>• Test the drive controller on a low power motor or without a motor: set OPL to nO. Refer to the <i>ATV31 Programming Manual</i>, FLT- menu.</li> <li>• Check and optimize the UFr (page 32), UnS (page 35), and nCr (page 35) parameters and perform auto-tuning (page 36).</li> </ul>
<p><i>D S F</i> Overvoltage during steady state operation or during acceleration</p>	<ul style="list-style-type: none"> <li>• Line voltage too high</li> <li>• Line supply transients</li> </ul>	<ul style="list-style-type: none"> <li>• Check the line voltage. Compare with the drive controller nameplate rating.</li> <li>• Reset the drive controller.</li> </ul>
<p><i>P H F</i> Input phase failure</p>	<ul style="list-style-type: none"> <li>• Input phase loss, blown fuse</li> <li>• 3-phase drive controller used on a single phase line supply</li> <li>• Input phase imbalance</li> <li>• Transient phase fault</li> </ul> <p><i>Note: This protection only operates with the drive controller running under load.</i></p>	<ul style="list-style-type: none"> <li>• Check the connections and the fuses.</li> <li>• Disable the fault by setting IPL to nO. Refer to the <i>ATV31 Programming Manual</i>.</li> <li>• Verify that the input power is correct.</li> <li>• Supply 3-phase power if needed.</li> </ul>
<p><i>S L F</i> Serial link failure Modbus</p>	<p>Loss of connection between drive controller and communication device or remote keypad.</p>	<ul style="list-style-type: none"> <li>• Check the communication connection.</li> <li>• Refer to the product-specific documentation.</li> </ul>

# J. MXFLOW FACTORY WIRING

ELECTRICAL SCHEMATIC, OUTDOOR KES LV10 & LV20 TERMINAL BOX, & ODOR SPRAY, OUTDOOR KES ENVIRO MOTOR CONTROL AND ANNUNCIATION CIRCUIT  
 CSA CERTIFIED

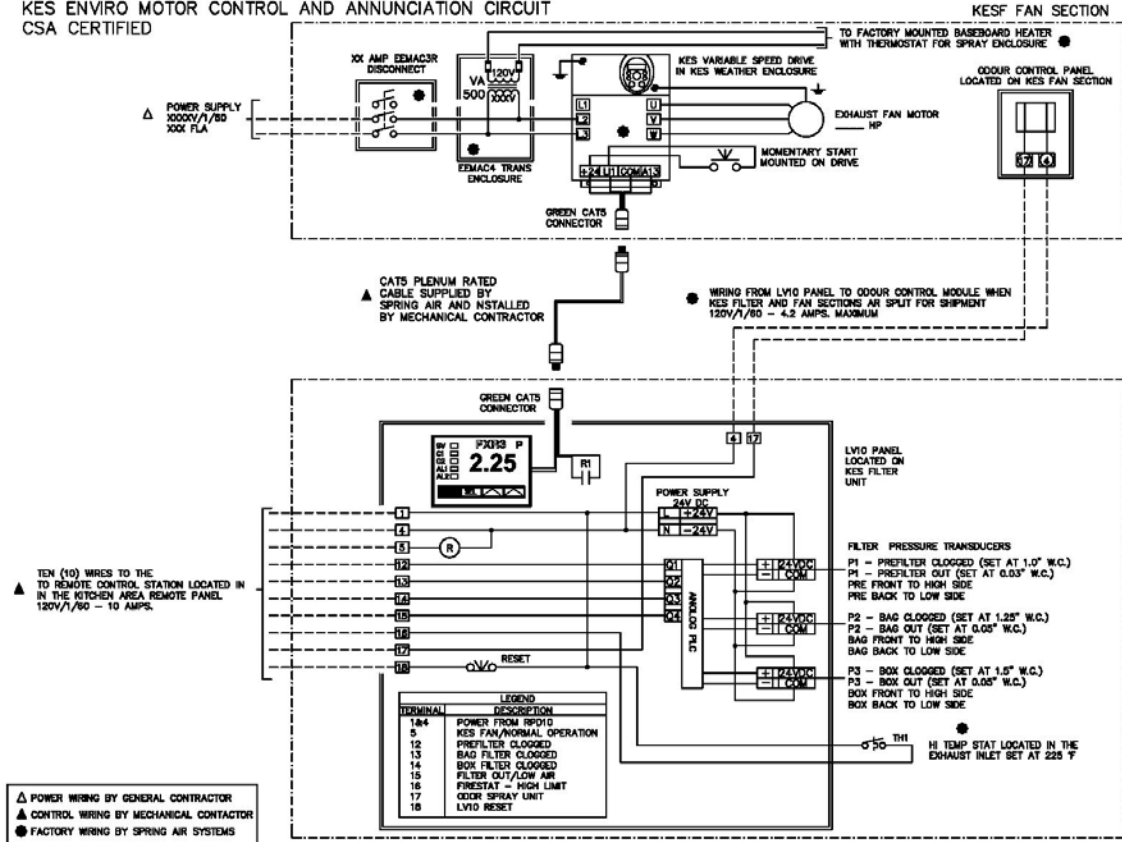

# K. PROGRAMMING THE SMART CLOCK

## Setting the Day and Time

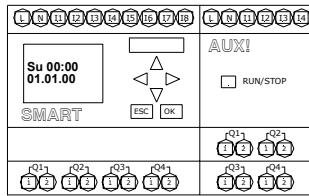

Su 00:00  
01.01.00

1. When power is first applied to the RPD10 panel the following display will blink. If the SERVICE FILTERS WITHIN 4 HOURS displays instead the OVERRIDE switch is on. Just rotate the switch and the correct display will blink.

>Stop  
Set Parma  
Set Clock  
Prg Name

2. Press **OK** and the following screen will appear.

Stop  
Set Parma  
>Set Clock  
Prg Name

3. Press **▽** twice.

Set Clock  
■Su 00:00  
MM.DD.YY  
01. 01. 00

4. Press **OK** and the following screen will appear.

Set Clock  
■Th 00:00  
MM.DD.YY  
01. 01. 00

5. To change the day press **△** until the correct day appears.

Set Clock  
Th 00:00  
MM.DD.YY  
01. 01. 00

6. To change the time press **▷** once. The hour will be highlighted. Press **△** or **▽** until the correct hour appears. Press **▷** to move to minutes. Adjust the minutes by pressing **△** or **▽** until correct minutes appears.

Set Clock  
Su 06:16  
MM.DD.YY  
01. 01. 00

7. To change the date press **▷** again. The month will be highlighted. Press **△** or **▽** until the correct month appears. Press **▷** to move to day. Adjust the day by pressing **△** or **▽** until correct day appear. Press **▷** to move to year. Adjust the year by pressing **△** or **▽** until correct year appears.

Set Clock  
Su 06:16  
MM.DD.YY  
01. 06. 03

8. You have finished setting the clock.

Su 06:16  
01. 06. 03

7. Press **OK** and **ESC** to return to the operating screen.

Setting the clock on RPD-KDA automatic panels  
Figure 31



## Setting the Weekend Fan "ON" and "OFF" times

- |  |  |
|--|--|
| <p>Su 06:16<br/>01. 06. 03</p>   | 1. Press <input type="button" value="ESC"/>  |
| <p>&gt;Stop<br/>Set Parma<br/>Set Clock<br/>Prg Name</p>                                 | 2. Press <input type="button" value="▽"/> once.  |
| <p>Stop<br/>&gt;Set Parma<br/>Set Clock<br/>Prg Name</p>                                 | 3. Press <input type="button" value="OK"/>   |
| <p>B04: No1<br/>D =MTWTFSS<br/>On = 06: 00<br/>Off = 23: 00</p>                          | 4. Press <input type="button" value="△"/> until the B04: No1 timer appears. This is the time setting for start and stop each weekday.  |
| <p>B04: No1<br/>D =MTWTFSS<br/>On = 06: 00<br/>Off = 23: 00</p>                          | 5. The clock has been factory set to turn the fan on at 6:00 a.m. and off at 23:00 hours or 11:00 p.m.   |
| <p>B04: No1<br/>D =<input type="checkbox"/>TWTFSS<br/>On = 06: 00<br/>Off = 23: 00</p>   | 6. To change the above settings press <input type="button" value="OK"/> The cursor will move to M = Monday.  |
| <p>B04: No1<br/>D = MTWTF-S<br/>On = 06: 00<br/>Off = 23: 00</p>                         | 7. Press <input type="button" value="△"/> to remove Monday from the weekly schedule. The - dash indicates the fan will not start automatically any given day.  |
| <p>B04: No1<br/>D = - TWTF--<br/>On = 06: 00<br/>Off = 23: 00</p>                        | 8. Press <input type="button" value="▷"/> to move to the next day of the week. Press <input type="button" value="△"/> each time the fan is not required to operate on that given day. The screen on the left indicates the fan will not automatically operate on Monday, Saturday or Sunday.   |
| <p>B04: No1<br/>D = - TWTF--<br/>On = <input type="checkbox"/>6: 00<br/>Off = 23: 00</p> | 9. Press <input type="button" value="▷"/> to move to the hour that the fan will start in the morning. Press <input type="button" value="▷"/> to change the hour you want the fan to start in each morning. Press <input type="button" value="▷"/> to move to the minute the the fan will start in the morning. Press <input type="button" value="△"/> to change the minutes. |
| <p>B04: No1<br/>D = - TWTF--<br/>On = 06: 30<br/>Off = <input type="checkbox"/>3: 00</p> | 10. Press <input type="button" value="▷"/> to move to the hour that the fan will stop in the evening. Press <input type="button" value="▷"/> to change the hour you want the fan to stop each evening. Press <input type="button" value="▷"/> to move to the minute the fan stop in the evening. Press <input type="button" value="△"/> to change the minutes.               |
| <p>B04: No1<br/>D = MTWTF--<br/>On = 06: 30<br/>Off = 22: 30</p>                         | 11. Press <input type="button" value="OK"/>  |
| <p>Su 06:16<br/>01. 06. 03</p>   | 12. If your selection is complete press <input type="button" value="ESC"/> and <input type="button" value="ESC"/> to return to the operating screen. You have completed programming one weekly fan "On" and "Off" cycling. If you wish to program a second (Weekend Operation) or third weekly setting go the the section "Setting Weekend Operation"                        |

Setting the Week Day Fan On and Off Timers on RPD-KDA automatic panels  
Figure 32

## Setting Weekend Operation

- |   |  |
|---|--|
| <p>Su 06:16<br/>01. 06. 03</p>  | 1. Press <input type="button" value="ESC"/>  |
| <p>&gt;Stop<br/>Set Parma<br/>Set Clock<br/>Prg Name</p>                      | 2. Press <input type="button" value="▽"/> once.  |
| <p>Stop<br/>&gt;Set Parma<br/>Set Clock<br/>Prg Name</p>                      | 3. Press <input type="button" value="OK"/>   |
| <p>B04: No2<br/>D = - - - - -<br/>On = - - : - -<br/>Off = - - : - -</p>      | 4. Press <input type="button" value="△"/> until the B04: No1 timer appears. This is the time setting for start and stop each weekday.  |
| <p>B04: No2<br/>D = ■ - - - - -<br/>On = - - : - -<br/>Off = - - : - -</p>    | 5. Press <input type="button" value="OK"/> to program the weekend operation.   |
| <p>B04: No2<br/>D = - - - - - SS<br/>On = - - : - -<br/>Off = - - : - -</p>   | 6. Press <input type="button" value="▷"/> five times to move to Saturday. Press <input type="button" value="△"/> to turn fan on Saturday. Press <input type="button" value="▷"/> once to move to Sunday. Press <input type="button" value="△"/> to turn fan on Sunday.   |
| <p>B04: No2<br/>D = - - - - - SS<br/>On = ■ - - : - -<br/>Off = - - : - -</p> | 7. Press <input type="button" value="▷"/> to move to the hour that the fan will start in the morning. Press <input type="button" value="△"/> to change the hour you want the fan to start in each morning. Press <input type="button" value="▷"/> to move to the minute the the fan will start in the morning. Press <input type="button" value="△"/> to change the minutes. |
| <p>B04: No2<br/>D = - - - - - SS<br/>On = 10: 00<br/>Off = ■ - : - -</p>      | 8. Press <input type="button" value="▷"/> to move to the hour that the fan will stop in the evening. Press <input type="button" value="△"/> to change the hour you want the fan to stop each evening. Press <input type="button" value="▷"/> to move to the minute the fan stop in the evening. Press <input type="button" value="△"/> to change the minutes.                |
| <p>B04: No2<br/>D = - - - - - SS<br/>On = 10: 00<br/>Off = 23: 30</p>         | 9. Press <input type="button" value="OK"/> If your selection is complete press <input type="button" value="ESC"/> and <input type="button" value="ESC"/> to return the operating screen.   |
| <p>Su 06:16<br/>01. 06. 03</p>  | 10. You have completed programming weekend fan "On" and "Off" cycling.   |

*Setting the and Weekend Fan On and Off Timers on RPD-KDA automatic panels  
Figure 33*

# L: SETTING THE FILTER OUT AND FILTER CLOGGED

## Introduction

This manual is for setting the PLC on the LV10 box for a KES unit without Truflow. The components of the LV10 are shown in Figure 34.

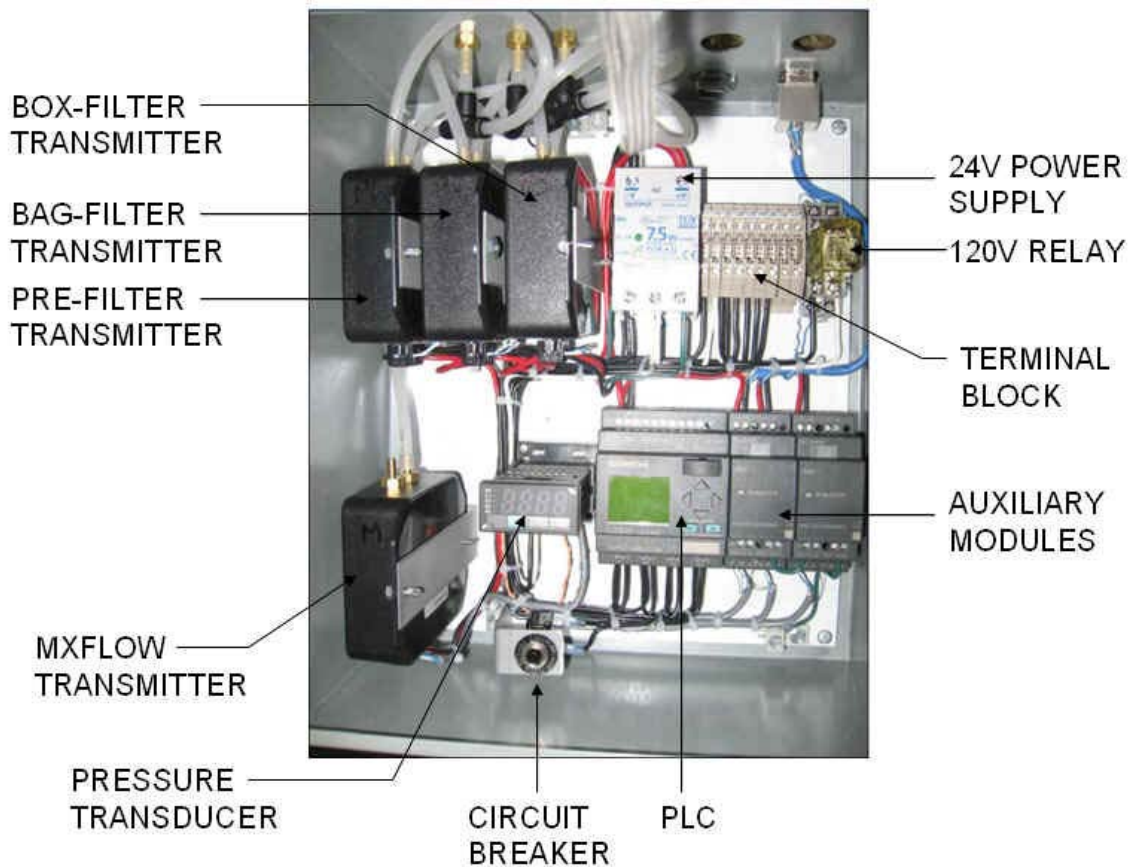

**Figure 34 – LV10 box**

Pressure Transmitter components are labeled in the LV10 panel as follows:

- P1: Pre-Filter Pressure Transmitter
- P2: Box-Filter Pressure Transmitter
- P3: Bag-Filter Pressure Transmitter
- MF: MXFLOW Pressure Transmitter

### SETTING THE FILTER OUT LIMITS AT STARTUP

The Filter OUT PCL setting for each KES unit may have to be adjusted during startup because each commercial kitchen exhaust system total pressure is not the same. The Filter Out (PRE OFF, BAG OFF and BOX OFF) settings must be adjusted below the current pressure reading (Ax) for the Prefilter, Bag Filter and Box Filter transmitter in the LV10. The LV10 PLC is used to adjust the setting of each pressure transmitter. All other functions are controlled by the PLC located in the RPD-KD or RPD-KW remote panel located in the kitchen area. The LV10 PLC interlocks to the RPD-KD or RPD-KW panel.

Note: Only the Filter Out limits for Pre-Filter (PRE O), Bag (BAG O) and Box (BOX O) filters must be checked at startup. The Filter Clogged limits are factory preset for the factory supplied filters.

The P1 (Prefilter), and P2 (Bag Filter) transmitters send a 4-20 ma signal to the Auxiliary 1 module attached to the PLC. The P3 (Box Filter) transmitter signals a 4-20 ma signal to the Auxiliary 2 module located next to Auxiliary 1 module. The PLC converts the 4-20 milliamp signals to a static pressure value. The P4 (MXFLOW) transmitter communicates with the PXR pressure transducer. See the MXFLOW section in this same manual for description of the MXFLOW operation.

### GETTING STARTED

Turn on the KES. Override the KES unit. The override switch is found on the remote RPD-KD or RPD-KW. When the KES is in override an amber pilot light on the RPD-KD or RPD-KW will flash.

Open the LV10 panel located on the filter section (KES-ISH). Proceed with caution as the panel is powered. When looking at the PLC screen in the LV10 for the first time it displays the date and time as shown in Figure 35. This is the main screen which serves as the basis for the following steps.

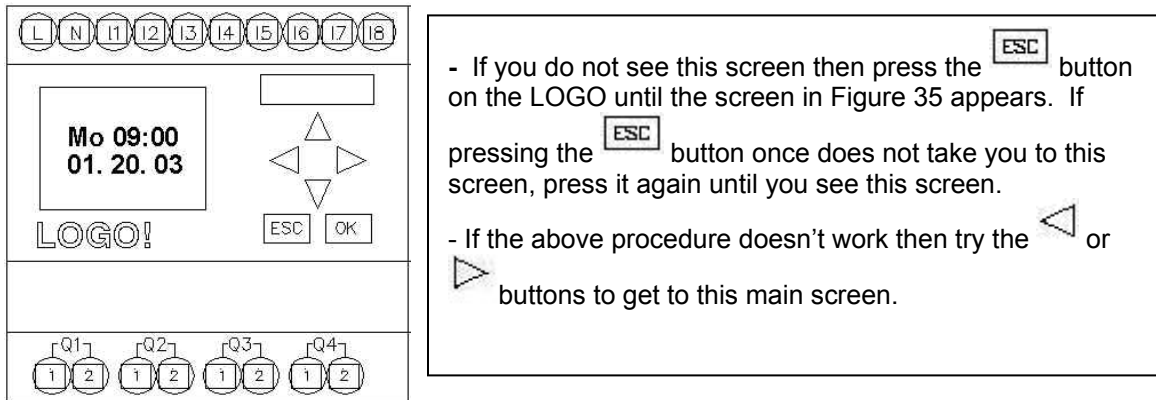

Figure 35

## VIEWING THE PARAMETERS

To set any parameter you must be on the Main Screen in Figure 35 to continue.

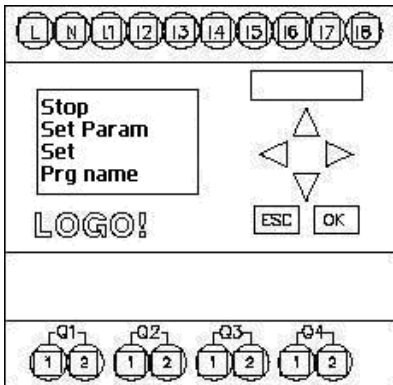
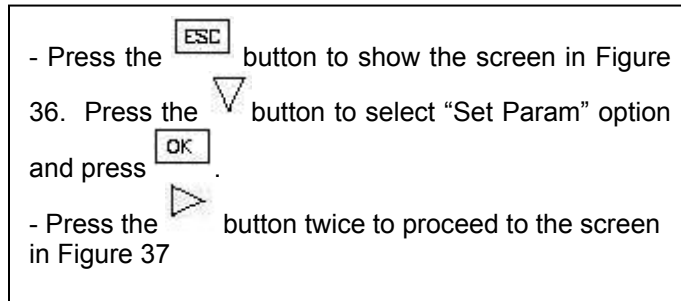

Figure 36



## FILTER OUT PARMETERS

The limits for the filter out are factory preset for each filter. You must verify that these limits are correct when the filter out does not activate properly. The Ax variable on each screen is the current pressure reading through the filter section. The current reading (Ax) must be higher than the "Off" limit setting for that filter. This limit determines whether the filter is out. To check if the Off limit is correct take that filter out. You will see a screen on the PLC displaying the static pressure the filter out occurred and the filter out pilot light on the RPD-K will turn on. Put the filter back in. This has to be done for each type of filter individually in the KES.

**Note: The values you set in the PLC MUST BE 100 times the actual static pressure. For example if you want the actual pressure limit to be 0.35" W.C., you need to input 35 in the PLC.**

## SETTING PRE-FILTER OUT (PRE O)

Factory Presets

On = -10

Off = 3

Ax = Current reading through this filter section with filter still in.

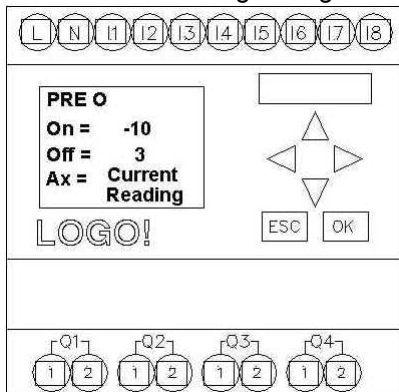
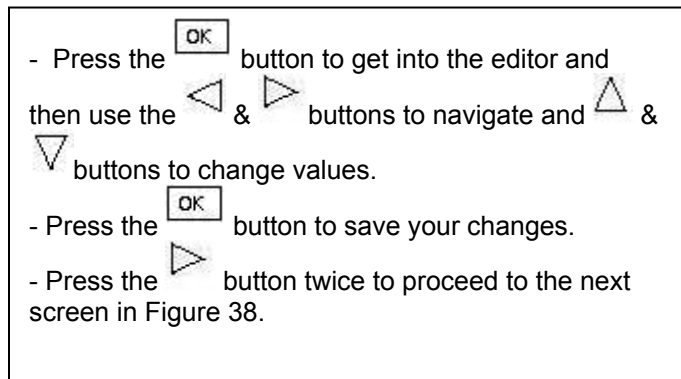

Figure 37



### SETTING BAG-FILTER OUT (BAG O)

Factory Presets

On = -10

Off = 5

Ax = Current reading through this filter section with filter still in.

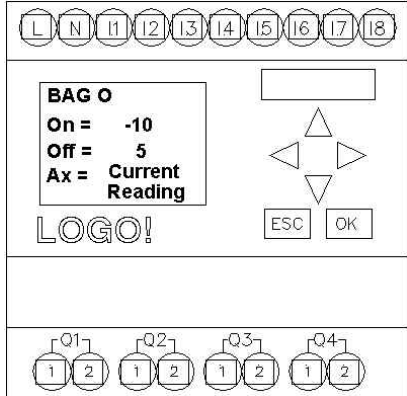

Figure 38

- Press the **OK** button to get into the editor and then use the **◀** & **▶** buttons to navigate and **▲** & **▼** buttons to change values.
- Press the **OK** button to save your changes.
- Press the **▶** button twice to proceed to the next screen in Figure 39.

### SETTING BOX-FILTER OUT (BOX O)

Factory Presets

On = -10

Off = 5

Ax = Current reading through this filter section with filter still in.

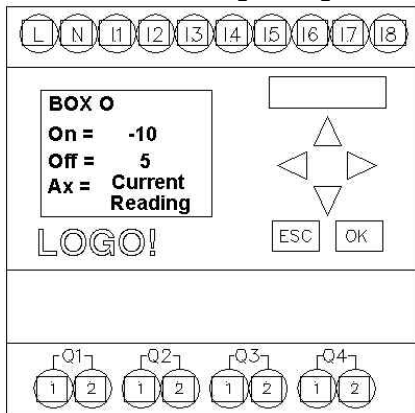

Figure 39

- Press the **OK** button to get into the editor and then use the **◀** & **▶** buttons to navigate and **▲** & **▼** buttons to change values.
- Press the **OK** button to save your changes.
- After finishing the setup press the **ESC** button twice to get to the main screen in Figure 40.

**Note:** There is a 5 second delay before the filter out or clogged is triggered.

## SETTING THE FILTER CLOGGED

The limits for the filter clogged settings are factory preset. These settings are the filter manufacturer recommended pressure limit at which the filters no longer continue operate efficiently. If you are replacing filters with an alternative manufacturer make sure you enter the new manufacturers pressure limits.

To change the filter clogged parameters go to screen in Figure 40 by following steps shown at the beginning of filter out setting section.

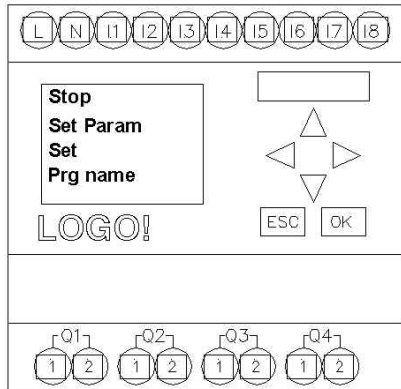



Figure 40

- Press the  button to select "Set Param" option and press .
- You will see screen shown in Figure 41.

## SETTING THE PRE-FILTER CLOGGED

Factory Presets

On = 100

Off = 95

Ax = Current reading through this filter section with filter still in.

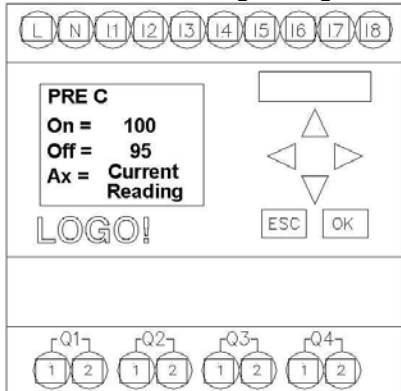









Figure 41

- Press the  button and then use the  &  buttons to navigate and  &  buttons to change values.
- Press the  button to save your changes.
- Press the  button twice to proceed to the next screen in Figure 42

### SETTING THE BAG-FILTER CLOGGED

Factory Presets

On = 125

Off = 100

Ax = Current reading through this filter section with filter still in.

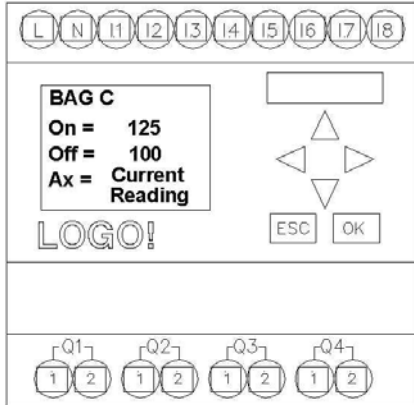

Figure 42

- Press the **OK** button to and then use the & buttons to navigate and & buttons to change values.
- Press the **OK** button to save your changes.
- Press the button twice to proceed to the next screen in Figure 43

### SETTING THE BOX-FILTER CLOGGED

Factory Presets

On = 150

Off = 125

Ax = Current reading through this filter section with filter still in.

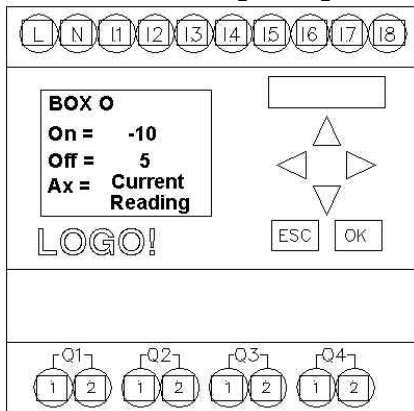
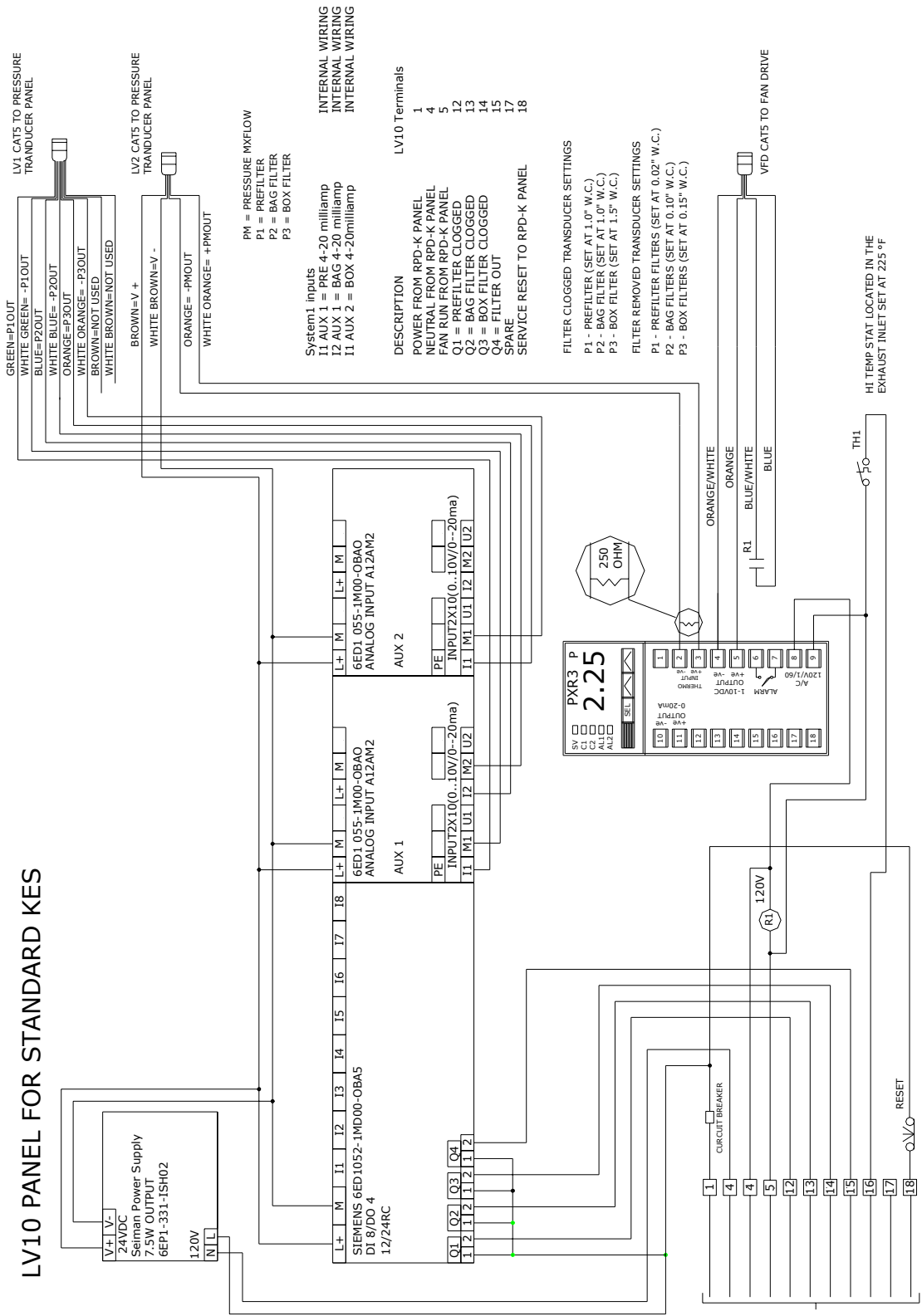

Figure 43

- Press the **OK** button to get into the editor and then use the & buttons to navigate and & buttons to change values.
- Press the **OK** button to save your changes.
- After finishing the setup press the **ESC** button twice to get to the main screen in Figure 35



# M: LOGO FACTORY WIRING



Logo Factory Wiring  
 Figure 43



**Spring Air**

# KES ENVIRO START-UP REPORT

## General Information

<b>Job Name</b>		<b>Date</b>	
<b>Location</b>		<b>File No.</b>	
<b>KES No.</b>		<b>Motor HP</b>	
<b>S/N</b>		<b>Voltage</b>	

Item	Description	Y / N
1	Check all electrical connections. Tighten as necessary	
2	(RPD-KD panels only) Check for power to the RPD-KD panel on terminals 1 & 4	
2a	Check all remote wiring to ensure it has been connected	
3	(RPD-KW panels only) Check wiring to terminals 1, 3 & 4 from water wash panel to RPD-KW remote	
4	LV10 J-Box wiring to terminal 1, 4 & 5 from RPD-KD- or RPD-KW remote	
5	LV10 J-Box wiring to terminal 4 & 5 to exhaust fan motor starter	
6	LV10 J-Box wiring to odor spray 4 & 17 (Optional for odor spray units)	
7	Power wiring to disconnect switch	

Check if all filters are in the unit

Type of Filter	Size	Qty
8	Prefilter 12" x 24" x 2"	
9	Prefilter 24" x 24" x 2"	
10	Bag Filter 12" x 24" x 22"	
11	Bag Filter 24" x 24" x 22"	
12	Box Filter 12" x 24" x 12"	
13	Box Filter 24" x 24" x 12"	

Item	Description	Y / N
14	Check of the inlet exhaust ductwork to the KES unit from the kitchen exhaust hood is all welded NFPA-96	
15	Check if clearance to top, sides, and ends of KES filter box is available: 18" to combustible or 6" to non-combustibles	
16	Check power at disconnect switch	3/60/ V

17A	<p><b>Non MXFLOW:</b> Check fan rotation as follows:            Turn on the main disconnect to the KESF fan motor starter            Turn "FAN ON" switch in the wash panel or remote RPD-KD panel to the ON position            Turn on the Override switch in the RPD-KD or RPD-KW remote panel. The LOGO text message "Service Filters within 4 hours" will appear.            Turn "FAN OFF" switch in the wash panel or remote RPD-KD panel to the OFF position. Observe the fan rotation. Change one of L1, L2 or L3 if fan is rotating backwards <b>AFTER DISCONNECTING ALL POWER TO THE KESF UNIT.</b></p>	
17B	<p><b>MXFLOW</b> units: Check fan rotation as follows:            Turn on the main disconnect to the KESF fan motor starter            Turn "FAN ON" switch in the wash panel or remote RPD-KD panel to the OFF position            Press the momentary pushbutton on/in the LV20 panel. The fan will rotate for the length of time the button is pressed. Observe the fan rotation. To correct fan rotation switch two of the high voltage wires on terminals V/T1, U/T2 or W/T3 on the drive or switch two wires at the motor. <b>AFTER DISCONNECTING ALL POWER TO</b></p>	

	<b>THE KESF UNIT.</b>			
18	Turn "FAN ON" switch in the wash panel or remote RPD-KD panel to the ON position			
19	Check the FLA	L1	L2	L3

20A	<b>NON-MXFLOW:</b> Adjust the overload setting on motor starter to FLA rating of motor			
20B	<b>MXFLOW:</b> The variable speed drives have a factory set overload setting			

**Alarm Circuit Check**

21	Turn "FAN OFF" switch in the wash panel or remote RPD-KD panel to the OFF position			
22	Rotate the OVERRIDE switch on the RPD-KD or RPD-KW to the original position. The text message will disappear once the fan is turned back on.			
23				
24	Turn "FAN ON" switch in the wash panel or remote RPD-KD panel to the ON position			

**Pre filter Clogged Test**

25	Jumper terminals 1 & 12 in the LV10 panel			
26	KES unit shuts off	Yes	No	
27	Prefilter clogged light on and LOGO text message "Change Prefilter"	Yes	No	
28	Rotate the OVERRIDE switch on the RPD-KD or RPD-KW on and off.			

**Bag Filter Clogged Test**

29	Jumper terminals 1 & 13 in the LV10 panel			
30	KES unit shuts off	Yes	No	
31	Bag clogged light on and LOGO text message "Change Bag filter"	Yes	No	
32	Rotate the OVERRIDE switch on the RPD-KD or RPD-KW on and off.			

**Box filter Clogged Test**

33	Jumper switch terminals 1 & 14 in the LV10 panel			
34	KES unit shuts off	Yes	No	
35	Box clogged light on and LOGO text message "Change Box Filter"	Yes	No	
36	Rotate the OVERRIDE switch on the RPD-KD or RPD-KW on and off.			

**Filter Removed Test**

37	Jumper switch terminals 1 & 15 in the LV10 panel			
38	KES unit shuts off	Yes	No	
39	Filter removed light on and LOGO text message "Filter Out or Low Exhaust"	Yes	No	
40re	Rotate the OVERRIDE switch on the RPD-KD or RPD-KW on and off.			

**Actual Filter pressure readings (See page 47 for description of how to read various pressure on LV10 PCL)**

41	Read the PRE O Ax		PRE O OFF	
42	Read the BAG O Ax		BAG O OFF	
43	Read the BOX O Ax		BOX O OFF	

**Confirming the KES unit Design CFM.**

Adjusting the PXR located in the LV10 panel on the filter box. Move the PXR set point value up or down until the BOX AX value reads \_\_\_\_\_.

**Filter Out Test #1**

44	Remove all the bag filters. Shut the access door and turn the unit on. Wait for 30 sec.			
45	KES unit shuts off	Yes	No	
46	Filter removed light on and LOGO text message "Filter Out or Low Exhaust"	Yes	No	
47	Reset unit at LV10 J-Box reset switch by turning on and off			
48	If the unit does not shut off adjust the BAG O OFF setting below the BAG O Ax reading. See page 47 of manual for description of changing the BAG O OFF setting. Once setting has been adjusted repeat item 44.			

**Filter Out Test #2**

49	Remove all the box filters. Shut the access door and turn the unit on. Wait for 30 sec.		
50	KES unit shuts off	Yes	No
51	Filter removed light on and RPD-KD or RPD-KW LOGO text message "Filter Out or Low Exhaust"	Yes	No
52	Rotate the OVERRIDE switch on the RPD-KD or RPD-KW on and off.		
53	If the unit does not shut off adjust the BOX O OFF setting below the BOX O Ax reading. See page 47 of manual for description of changing the BOX O OFF setting. Once setting has been adjusted repeat item 44.		

**Hi Temperature Switch Test**

54	Jumper terminals 1 & 16 in the LV10 J-Box.		
55	KES unit shuts off	Yes	No
56	Fire light on	Yes	No
57	Rotate the OVERRIDE switch on the RPD-KD or RPD-KW on and off.		

**Check override switch**

45	Turn "FAN OFF" switch in the wash panel or remote RPD-KD panel to the OFF position		
46	Jumper terminals 1 & 12 in the RPD-KD or RPD-KW.		
47	Turn "FAN ON" switch in the wash panel or remote RPD-KD panel to the ON position		
48	After 30 seconds the KES shuts off, the Prefilter Clogged light turns on and the LOGO text message "Prefilter Clogged" will appear.		
49	Rotate the OVERRIDE switch on the RPD-KW or RPD-KD remote panel to the ON position.		
50	KES unit turns on	Yes	No
51	Warning light turns on and the LOGO text message "Service Filters within 4 hours" will appear.	Yes	No
52	Turn "FAN OFF" switch in the wash panel or remote RPD-KD panel to the OFF position		
53	Remove the jumper		
54	Turn "FAN ON" switch in the wash panel or remote RPD-KD panel to the ON position		
55	Rotate the OVERRIDE switch on the RPD-KW or RPD-KD remote panel to the OFF position. The Warning light goes off and the LOGO text message disappears.		

56A	<b>NON-MXFLOW:</b> Measure the exhaust air volume at each hood Use hood start up form for this. Adjust air volume to suit with change of pulleys.
-----	--

56B	<b>MXFLOW:</b> Measure the exhaust air volume at each hood Use hood start up form for this. Once the exhaust volume is measured the volume can be adjusted on site with the DMP. See page 16 of this manual for adjustment.
-----	--

**Comments:**

Service Technician: \_\_\_\_\_

Yes I have received a set of Spring Air Systems Inc. maintenance manuals.

Signature \_\_\_\_\_ Print Name \_\_\_\_\_

## Other Fine Products From

# SPRING AIR SYSTEMS...

- Water Wash Ventilators
  - ◆ Hot Water Wash
  - ◆ Cold Water Spray/Hot Water Wash
  - ◆ Water Wash Control Panels
- Dry Extractor Hoods
- **RevLow** Hoods
- **Dynaflow** Hoods
- Cartridge Hoods
- Filter Hoods
- Surface Fire Suppression
- Commercial Kitchen Exhaust Fans
- Kitchen Enviro Systems
  - ◆ KES - 100% Exhaust
  - ◆ KRS - 80% Recirculation in Canada
- Commercial Kitchen Supply Units
- Compensating Hoods
- Exhaust Fans
- **Zoneflow** Kitchen Exhaust Balancing Dampers
- Supply Fans
- Commercial Kitchen Control Panels
- TruFlow Variable Speed Exhaust/Supply Systems
- Utility Distributions Systems