



KES Enviro Redivent Installation, Operating and Maintenance Manual

July 2015

Spring Air Systems Inc.

Phone (905) 338-2999, Fax (905) 338-0179, info@springairsystems.com
www.springairsystems.com

KES Enviro Installation, Operating and Maintenance Manual

Table of Contents

| | |
|---|----|
| Introduction | 3 |
| The System | 4 |
| Control Circuit | 5 |
| Control Systems: Filter hood or Dry Extractor Remote | 10 |
| Checking Fan Rotation | 12 |
| Odor Spray System | 12 |
| Where to Purchase Filters | 15 |
| Replacement Filter Equivalents | 15 |
| When to Change the KES Filters | 16 |
| Trouble Shooting | 18 |
| KES Maintenance Schedule | 20 |
| Programming the Smart Clock | 22 |
| Setting the weekend fan and operation | 23 |
| Setting filter out limits at start-up | 25 |
| Viewing Parameters | 26 |
| Setting Bag and Box Filter | 27 |
| Setting Filter and Pre-Filter Clogged | 28 |
| Setting Bag and Box Filter Clogged | 29 |
| Appendix A: VFD only: Factory Drive Terminal Schematic | 30 |
| Appendix B: Hazardous Warning | 32 |
| Appendix C: VFD only: Good Wiring Practice | 33 |
| Appendix D: VFD only: Grounding | 34 |
| Appendix E: VFD only: Starting the Drive | 35 |
| Appendix F: VFD only: Accessing the drive program menu | 36 |
| Appendix G: VFD only: Programming the Drive Parameters | 38 |
| Appendix H: VFD only: Trouble shooting the Drive Faulty Display | 39 |
| KES Enviro Redivent Start-Up Report | 44 |

July 2015

KES ENVIRO OPERATION AND MAINTENANCE MANUAL

INTRODUCTION

Thank you for purchasing a Spring Air Systems commercial kitchen ventilation product. Please read the complete "KES Enviro Operation and Maintenance Manual" prior to installation, commissioning or operating a KES unit.

The SPRING AIR SYSTEMS INC. kitchen Enviro system (KES), Exhaust Cleaning Assembly for Kitchen Exhaust Duct, "Enviro Unit" is ULC and UL listed for use in a commercial kitchen exhaust system. KES units are available in sizes ranging from 1,000 CFM to 10,000 CFM for indoor applications.

The primary function of a KES Enviro unit is to filter the grease, lint and dust particles and remove the odor from the exhaust air.

The Underwriters Laboratories Inc. (UL) and Underwriters' Laboratories of Canada Limited (ULC) listings allow the kitchen exhaust air to be discharge to atmosphere at low levels.

Prior to any installation the installer must seek approval from the authorities having jurisdiction.



KES-ISH Enviro Filter Box
Figure 1

KESF Enviro Fan Box
Figure 2

KES System
Schematic Figure 3

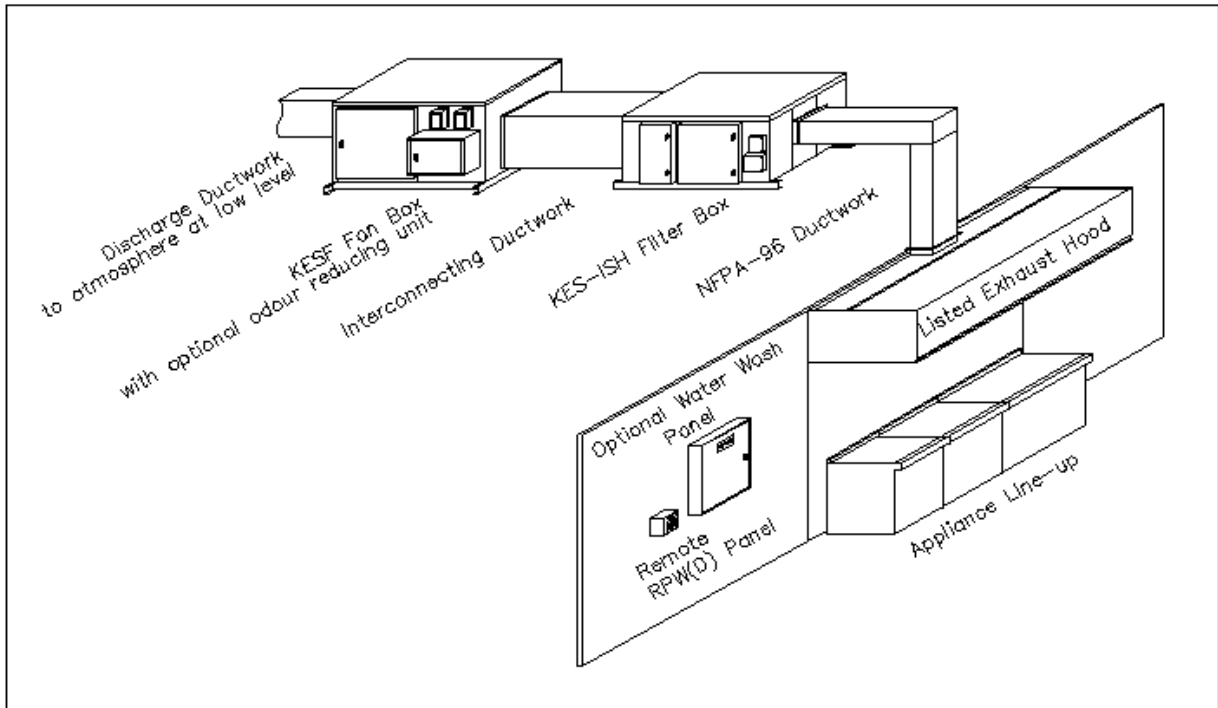

THE SYSTEM

The grease-laden air rises from the cooking equipment into a UL or ULC exhaust hood. The exhaust hood removes some of the airborne grease particulate. Typically most micron and submicron particles escape into the exhaust ductwork. The exhaust ducting is connected from the hood to the inlet of the KES Enviro unit. This exhaust ductwork must be supplied and installed in accordance with the NFPA-96 code.

Once through the particulate filter sections the exhaust air enters the optional odor removal section. The odor section is only required when discharging cooking smells may be offensive. This section consists of two optional odor removal systems.

1. Odor Cells filled with activated alumina impregnated with potassium permanganate. The odor is controlled through a combination of sorption and the chemical modification of the gaseous contaminants. The odor media is non-toxic and non-flammable.
2. Odor spray solution. The odor is control by spraying an odor reducer into the exhaust air stream intermittently during the operation of the cooking systems. The odor spray unit is normally located mounted on the KESF fan section. The cabinet includes an air compressor, atomizing air nozzle and piping and odor spray container.



Odor Spray components
Figure 4

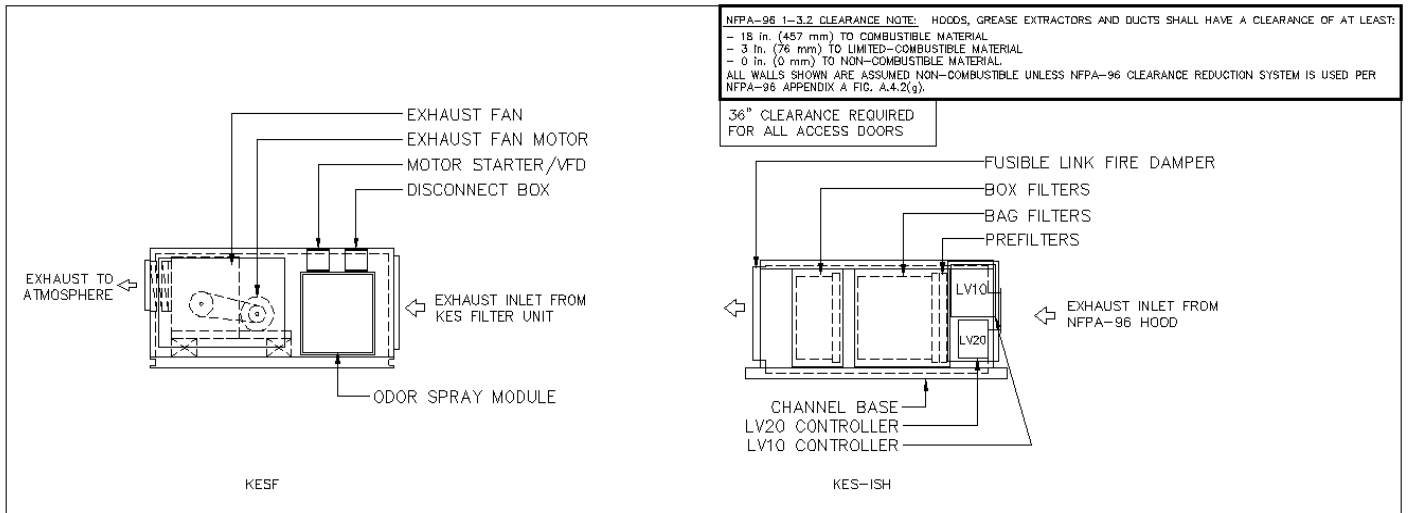

KES-ISH and KESF Enviro components
Figure 5

The exhaust air is discharged from the KES unit through a single width, single inlet (SWSI) or double width, double inlet (DWDI) exhaust fan. The discharge ductwork transfers the exhaust air outdoors.

CONTROL CIRCUIT

Filter Clogged:

During normal operation of the KES unit three-filter stages collect grease, dust, and lint particulate. The type of cooking equipment and the hours of operation determines the useful life of the individual filters.

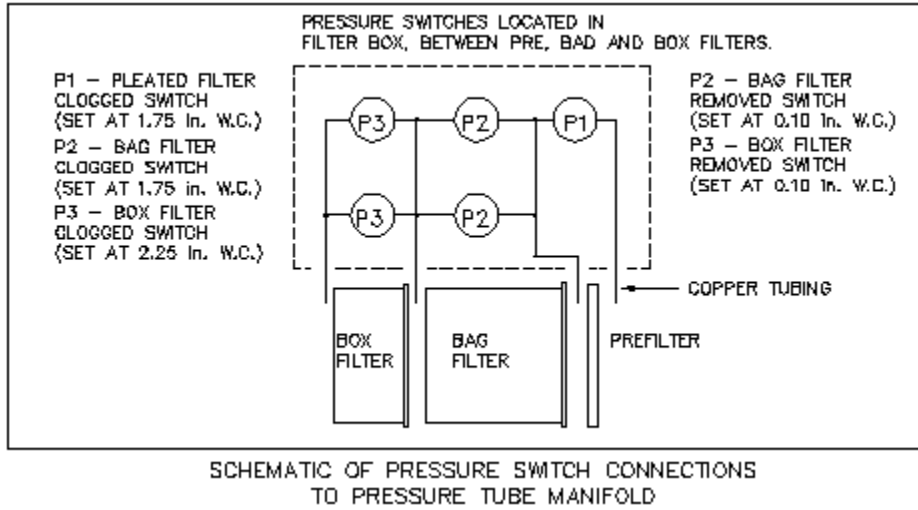

Pressure Switch Locations Figure 6



*Box Filter probes as viewed
from discharge
Figure 7*

ELECTRICAL SCHEMATIC, INDOOR KES LV10 TERMINAL BOX, & ODOUR SPRAY KES ENVIRO MOTOR CONTROL AND ANNUNCIATION CIRCUIT
CSA CERTIFIED

△ POWER WIRING BY GENERAL CONTRACTOR
▲ CONTROL WIRING BY MECHANICAL CONTRACTOR
● FACTORY WIRING BY SPRING AIR SYSTEMS

NOTE 1:
ALL REMOTE ELECTRICAL WIRING SHALL CONFORM TO ALL LOCAL AND NATIONAL CODE REQUIREMENTS

CALL SPRING AIR SERVICE AT 1-866-874-4505 IF YOU HAVE ELECTRICAL WIRING QUESTIONS

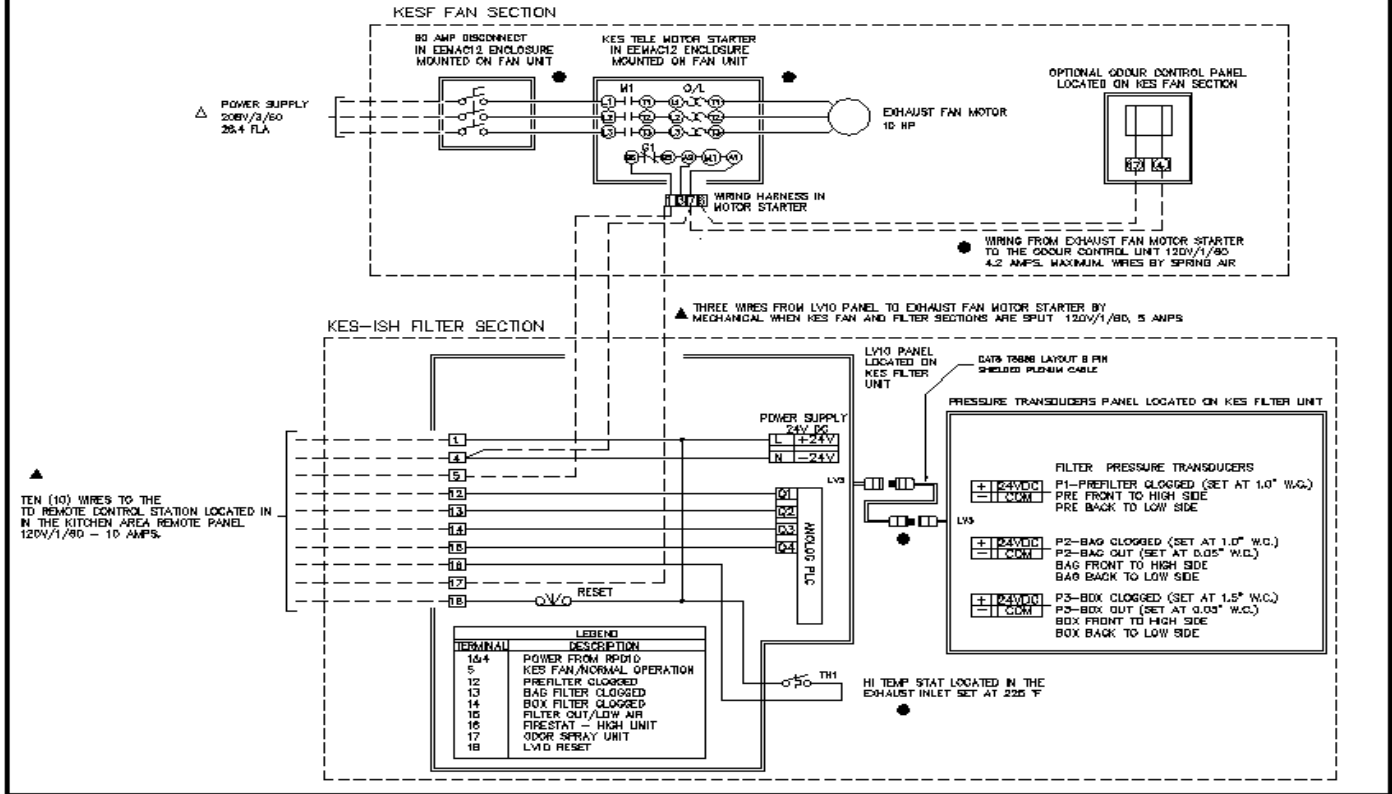

Typical indoor KES, motor starter, LV10 J-Box with odour spray wiring schematic
Figure 8

Pressure transducers have been installed to determine when the filters are totally used and must be replaced. As the filter reaches the grease loading capacity the static pressure across each filter increases. When the maximum static pressure is reached the pressure alarm is activated. The exhaust fan shuts off, the "NORMAL" pilot energizes, and the kitchen remote panel annunciates a filter-clogged condition. (The remote panel indicates which stage of filters has clogged; PREFILTER, BAG FILTER, or BOX FILTER.) In addition the screen of the LOGO controller in the RPD10 or RPW10 has a text message also indicating which filter is clogged.

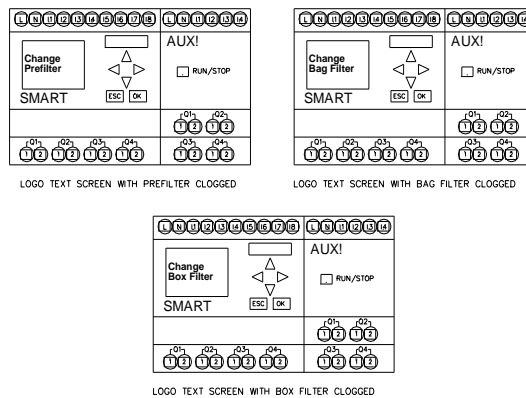

RPD10 or RPW10 LOGO controller indicating Box Filter clogged text messages
Figure 9

The clogged filter must be replaced and the system reset to resume normal operation. If this condition occurs during normally operating hours rotate the OVERRIDE selector switch and the fan will come back on. The systems can run in the OVERRIDE position for about 4 hours. (See the section the OVERRIDE switch) If the system runs longer than 4 hours the fan will shut down. The filters must be changed and the system reset. It is recommended that the filters be changed prior to the filter clogged light energizing. A filter usage chart is attached to record when the filters are being changed. Using this chart a regular maintenance schedule can be set up to ensure constant uninterrupted operation of the commercial kitchen.

Filter Removed:

Should the bag or box filters be removed during normal operation the KES unit is automatically shut down. A pressure transducer across the bag filters and box filters monitors a minimum pressure drop of 0.25" W.C. When the filter is removed the pressure differential falls and the pressure switch is activated. The exhaust fan shuts off, the "FILTER REMOVED" pilot light on the RPD10 or RPW10 energizes and the screen of the LOGO controller in the RPD10 or RPW10 has a text message indicating "FILTER REMOVED/LOW EXHAUST. To resume normal operation the filter must be replaced and the system reset. (See the section the OVERRIDE switch)

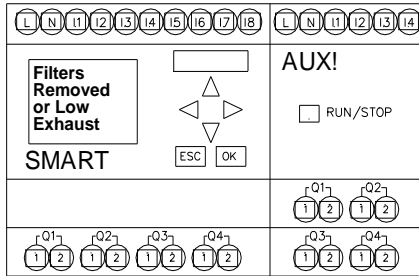

*RPD10 or RPW10 LOGO controller indicating filter removed text message
Figure 10*

Fire:

In the event of a high temperature in the ductwork leading to the KES unit or within the KES unit a firestat located at the inlet of the KES filter section is activated. When the exhaust air reaches 160 F the firestat is energized. The exhaust fan shuts off, the "NORMAL" pilot goes off, and a "FIRE" pilot energizes on the remote RPD10 or RPW10 panel. Should the exhaust temperature continue to rise the fusible link melts and closes the fire damper in the exhaust discharge of the KES filter section. This fire damper is always located between the fan and filter section. The fire damper fusible link is rated at 165 F. Shut off all cooking equipment and notify the fire department. To resume normal operation, replace the fusible link and reset the system. An authorized SPRING AIR SYSTEM INC. service technician should be called to inspect the unit.

Override Switch: (located on RPW10 or RPD10 panel)

In the event that the filter clogged annunciation shuts off the KES unit during a peak cooking time rotate the OVERRIDE SWITCH located on the RPW10 panel clockwise. The WARNING pilot light will energize and the FILTER CLOGGED and NORMAL lights will turn off. This is a temporary override to allow for the cooking equipment to be shut off prior to changing the filters. The systems can run in the OVERRIDE position for 4 hours. If the system runs longer than 4 hours the fan will shut down. The filters must be changed and the system reset. It is recommended that the filters be changed prior to the filter clogged light energizing. A filter usage chart is attached to record when the filters are being changed. Using this chart a regular maintenance schedule can be set up to ensure constant uninterrupted operation of the commercial kitchen.

Once the dirty filter has been replaced rotate the OVERRIDE SWITCH to counter clock wise to resume normal operation.

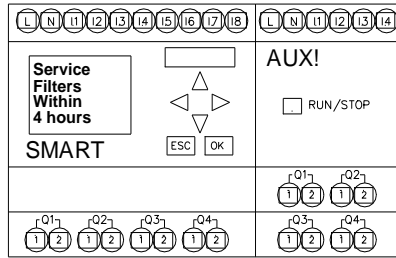

*RPD10 or RPW10 LOGO with Override selector in on position
Figure 11*

System Reset:

After any of the safety circuit annunciation, the system must be reset. The system is reset by toggling the “RESET” switch in the LV10 J-box, or switching the OVERRIDE SWITCH on the RPW10 or RPD10, or turning the fan selector switch to the “OFF” and then to the “ON” position.



*Logo Processor
Figure 12*



RPD-KD & RPD-KW Face Plate
Figure 13

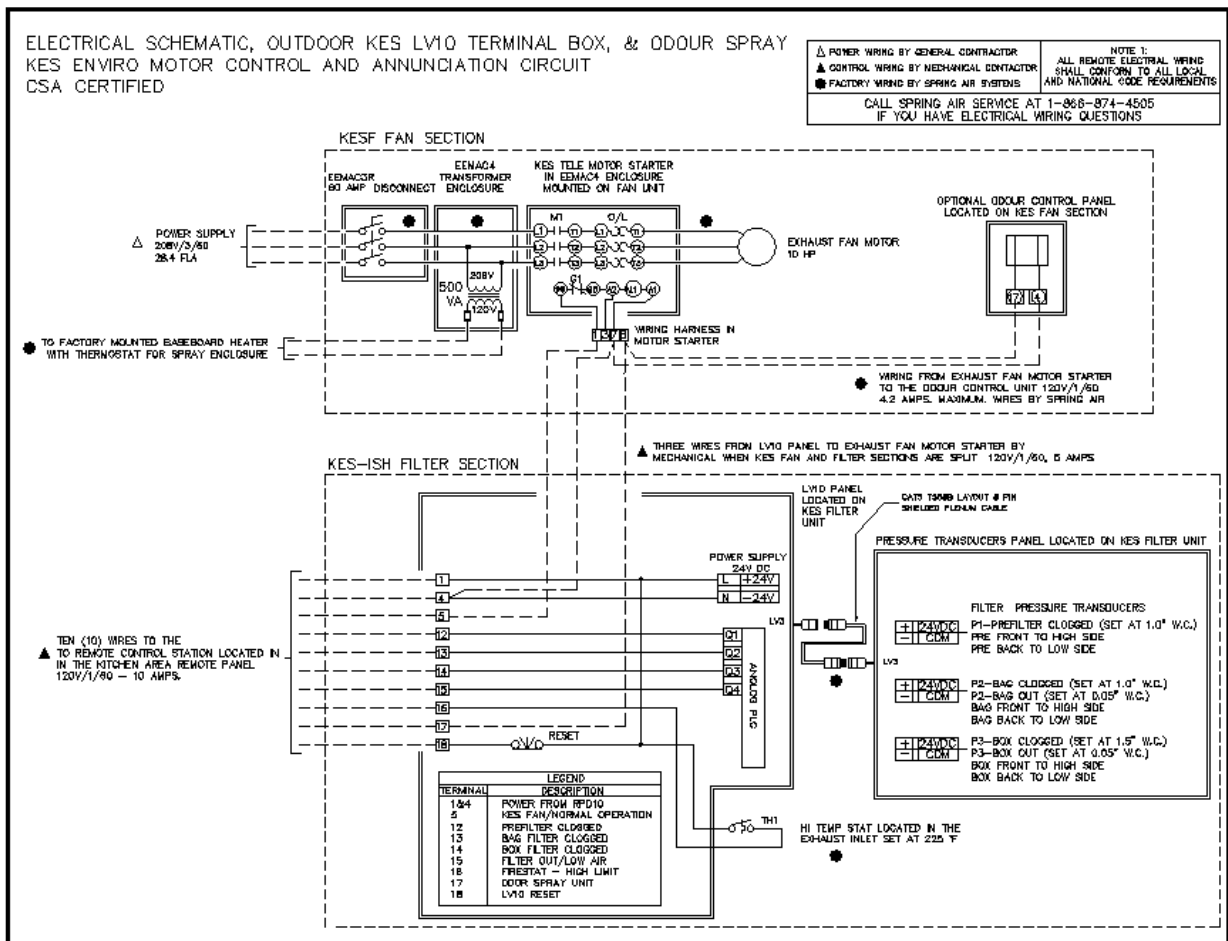

Wiring diagram for Outdoor KES, motor starter, LV10 J-Box, and odor unit
Figure 14

CONTROL SYSTEM

FILTER HOOD OR DRY GREASE EXTRACTOR:

RPD10 Remote Panel

The KES unit off/on operation is controlled from RPD10 remote annunciation panel. The fan selector switch on the RPD10 remote panel closes and sends power through terminals 5 & 4 to the LV10 J-Box to energize the exhaust fan circuit. (The LV10 J-Box is mounted on the KES-ISH filter section). The "NORMAL" operation pilot on the RPD10 remote kitchen annunciation panel energizes and after 30 seconds the KES control circuit within the RPD10 remote panel is activated. The exhaust fan motor is energized through the terminals 5 & 4 to the motor starter. See figure 8 for the RPD10 remote panel wiring and figure 9 for dimensions.

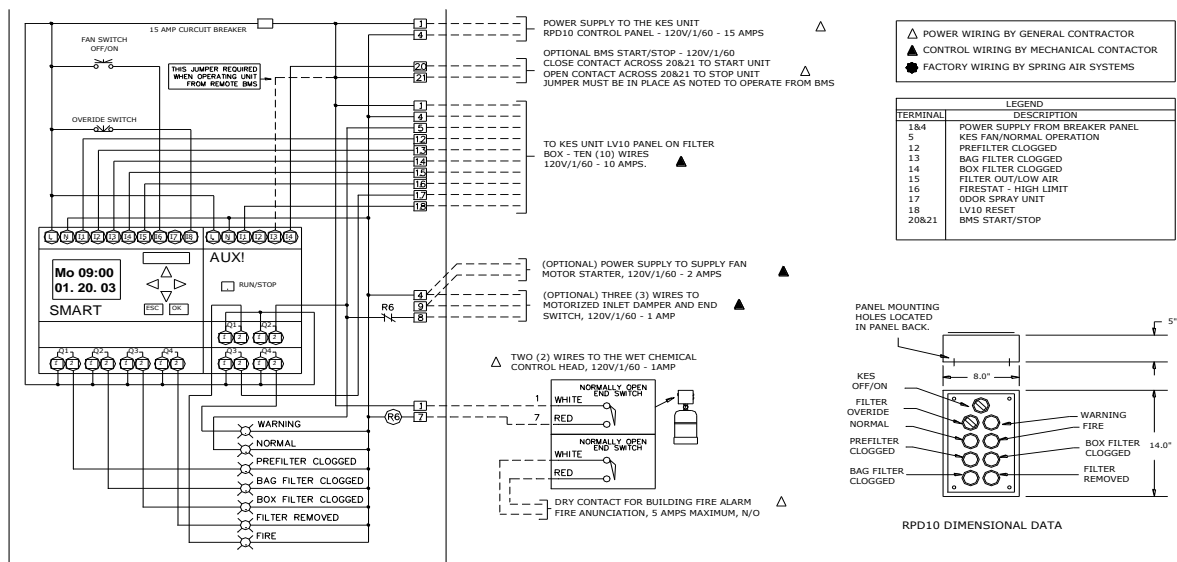

RPD10 Wiring Schematic
Figure 15

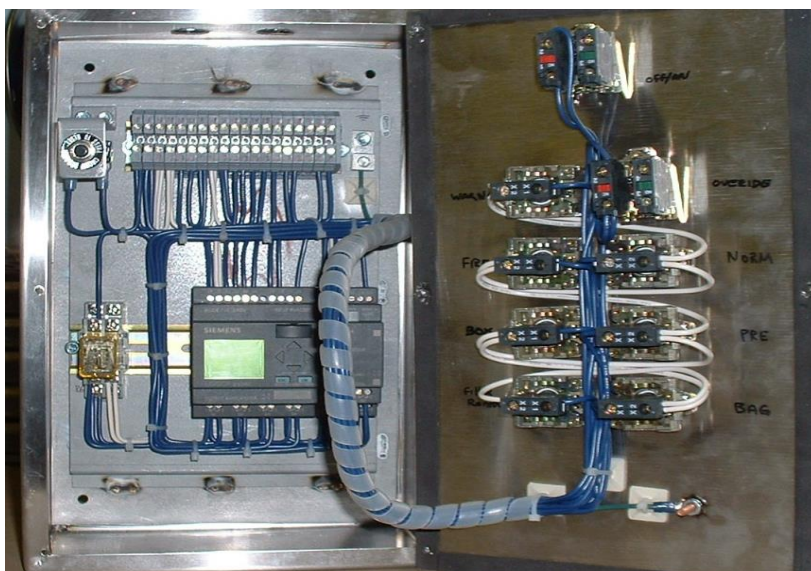

RPD10 Internal Wiring
Figure 16

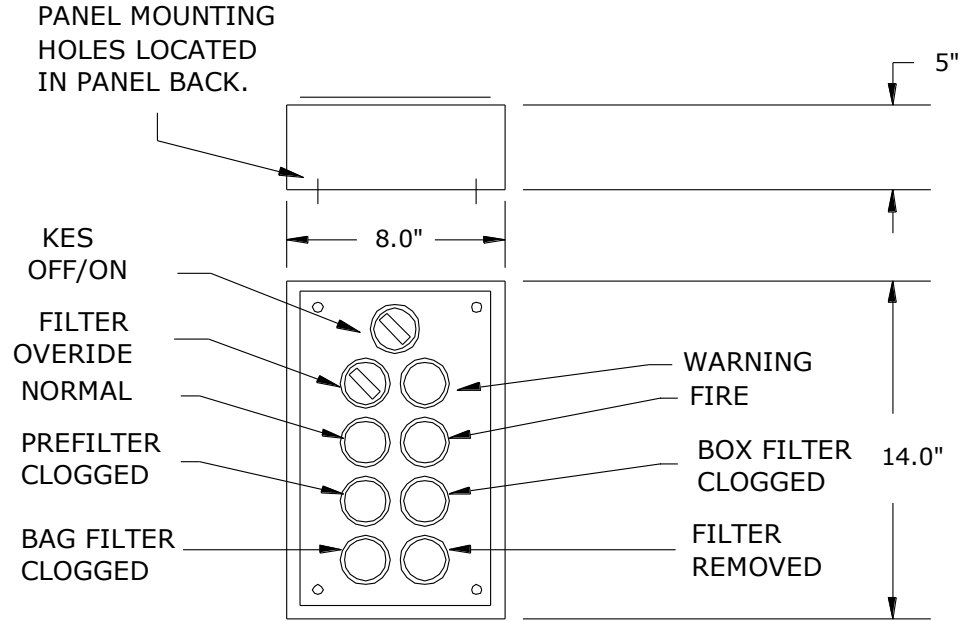

RPD10 Remote Panel Dimensions
Figure 17

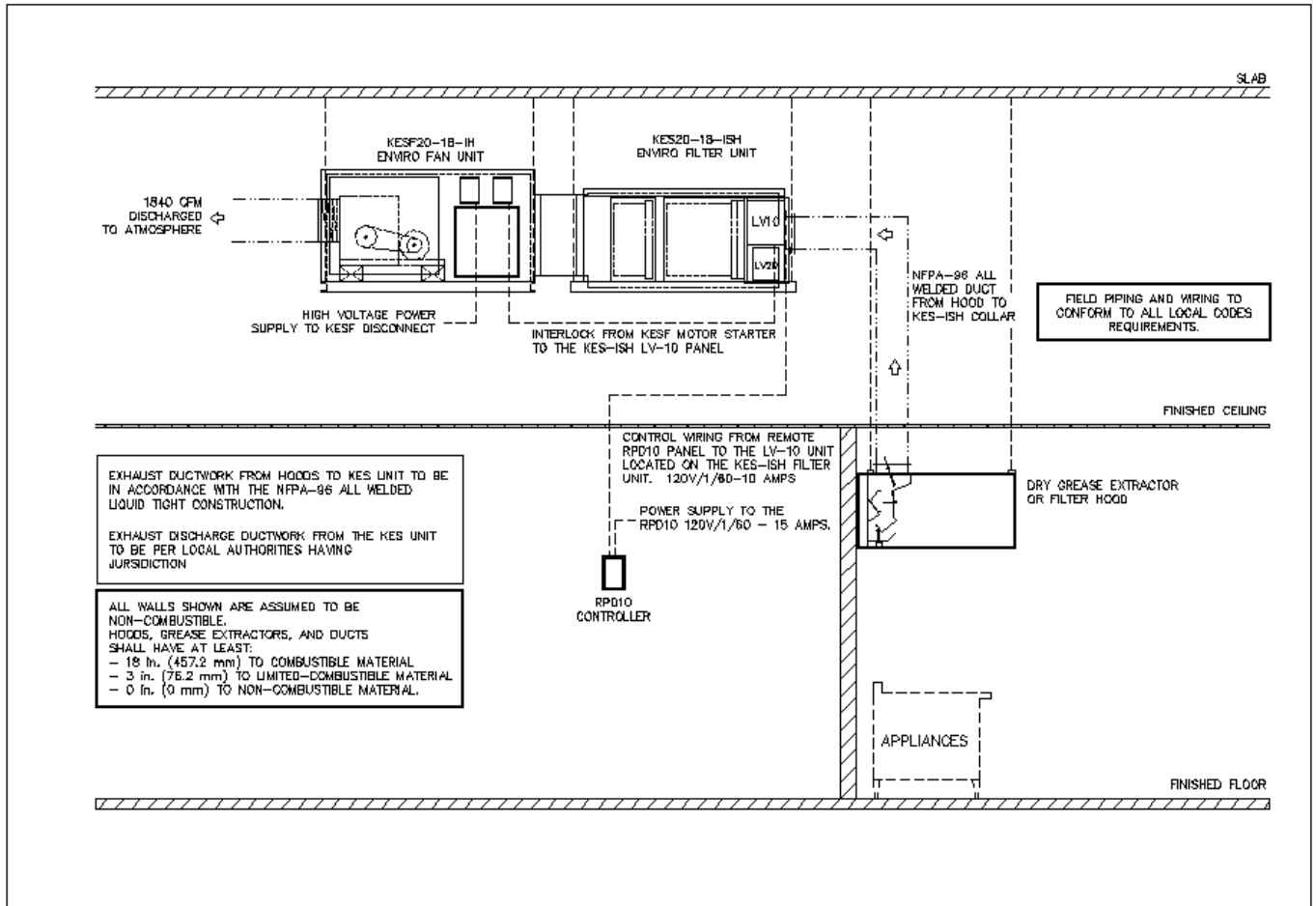

Remote wiring of KES Enviro units with Dry Hood
Figure 17

CHECKING FAN ROTATION

Fan rotation should be checked prior to commission the system. Turn the fan selector switch in to the off position. Turn on the circuit breaker powering the KESF unit. To check fan rotation, turn off disconnect at KES, turn on unit at RPD panel, turn on disconnect to roll fan, then shut off disconnect and verify rotation. The backward inclined KESF fan must be running backwards such that the fan blades pushing the air from the back of the blade. If the fan is scooping the air change the fan rotation. To correct fan rotation switch two of the high voltage wires on terminals at motor starter or switch two wires at the motor.

SHUT OFF ALL POWER TO THE KESF BEFORE CORRECTING ROTATION



*A KESF DWDI fan. Correct rotation for this fan arrangement looking into the end shown above is clockwise
Figure 18*

ODOR SPRAY SYSTEM

Operating and Maintenance

The Spring Air Systems Inc. odor spray unit has a one-year warranty from startup. The two timers, cycle timer B01, and spray timer B02, are factory set (5 minute cycle and 2 second spray) and then adjusted during startup to the odor reducing intensity required for the application. The B01 cycle timer is generally set between 5 to 10 minutes. The B02 spray timer is generally set between 2 to 60 seconds.

How does it Work?

The odor spray setting is a qualitative measurement. The spray timers are field set to provide adequate odor reduction for the installation. This is completely subject to what a particular person feel is an acceptable discharge odor.

During the spray timer activation the combination air compressor and air-atomizing nozzle injects a volume of odor solution into the exhaust discharge. This solution is carried along the discharge duct and vented to atmosphere. The spray solution chemically activates with the kitchen exhaust air to reduce the kitchen exhaust odors. As the solution is carried down the duct some adheres to the duct walls. We will call this the spray residue. During the cycle time when the spray is not activated this spray residue continues the odor reducing process as the exhaust air passes. Therefore installation with longer discharge ducts can normally use a longer cycle time because there will be more spray residue. A shorter run of discharge duct usually results in shorter cycle time.

- A. When adjusting the timers the object is to use as little spray solution as possible to provide adequate odor reduction:
1. First adjust the spray cycle, B01 timer.
 2. Reduce this setting by $\frac{1}{2}$ of the original cycle setting and check the operation. If $\frac{1}{2}$ proves adequate, increase the cycle back to $\frac{3}{4}$ of the original cycle setting. If this is adequate increase to $\frac{7}{8}$ of the original setting and so forth.

3. If reducing the setting by $\frac{1}{2}$ is not adequate decrease the cycle to $\frac{1}{4}$ of the original setting. If this is not adequate adjust the spray timer B02.
 - a. Increase the spray time B02 in increments of 5 seconds. After each 5 second increase evaluate the quality of the exhaust discharge air to determine if it is acceptable to the user.
 - b. When the spray timer setting equals the cycle timer settings the spray will be continuous. The maximum setting of B02 should not exceed the cycle timer B01.

The odor spray bottle must be changed regularly depending on the length of time set on timers B01 and B02. The odor spray line from the spray bottle to the spray nozzle must be cleaned every 6 months in a water and detergent mixture. The compressed air gauge should read between 10 and 15 psi. When the air gauge is reading below 10, psi will clean out the compressed air line. If the pressure is still low proceed to the next step compressor maintenance.

When there is odor in adjoining floors or office spaces

A kitchen located in the interior of an office building must be very negative to keep the kitchen odor within the kitchen. We recommend the kitchen be a minimum 20% negative. The fresh air supply is 80% of the total exhaust air from the kitchen space. When there is odor in adjoining spaces check the following.

1. The kitchen is not negative enough to keep the smell of the kitchen in the kitchen. If this is the case the odor is usually present all the time, even when there is no cooking. Reduce the amount of fresh air to the kitchen by adjusting the supply fan volume.
2. The kitchen may be connected to the same building A/C unit as the rest of the floor. If this is the case the return air grilles in the kitchen draws the kitchen odor to the main A/C unit and disperses the odor throughout the floor. The main A/C return must be blocked from the kitchen and put on a separate A/C unit.
3. The floor above the kitchen have odor. There are three possibilities.
 - a. The exhaust shaft is not sealed and the kitchen exhaust is leaking out onto the floors above the kitchen. Either adjust the amount of odor spray per section "An" above, or install an exhaust fan on the roof to draw the kitchen exhaust to the roof and maintain a negative pressure in the discharge duct.
 - b. The odor may escape when the kitchen is not operating during the night. After the kitchen is shut off kitchen odor may migrate up the exhaust duct and leak out into the adjoining floors. This can be solved by operating the kitchen exhaust for a couple hours after the cooking has stopped for the day and starting the kitchen exhaust fan an hour before cooking starts in the morning.

Odor Spray Compressor Maintenance

Do not, at any time lubricate any of the parts with oil, grease, or petroleum products nor clean with acids, caustics or chlorinated solvents. Be very careful to keep the diaphragm from contacting any petroleum product of hydrocarbons. It can affect the service life of the pump.

To clean or replace the filters and/or rubber gasket, remove the five screws in the top of the unit. The filters and gaskets are located beneath this top plate. Remove the filters and wash then in a solvent and/or blow off with air and replace. The gasket may be cleaned with water. Replace the filters in proper position and replace the gasket. Note that the gasket and top plate will fit in one position only.

To replace the diaphragm, remove the socket cap screws from the head of the pump. The diaphragm is held in place by two Philip head screws. Remove screws, retainer plate, and diaphragm. The diaphragm will fit in any position on the connecting rod. Replace the plate and the two Phillips head screws. Torque to 30 inch-pounds on DOA and DAA.

Caution: Do not raise any burrs or nicks on the heads of these screws. These burrs could cause damage to the inlet valve.

For replacing the inlet and outlet valve, remove the slotted machine screw that holds each valve in place. The stainless steel inlet and outlet valves are interchangeable. Clean them with water. When replacing the outlet valve, place the new valve in location and note there is a retaining bar near the machine screw hole. This retaining bar holds the valve in position. When replacing the inlet valve, note that the valve holder is marked with an X in one corner. This X should be in the lower right hand corner toward the inlet of the air chamber. Replace the head and tighten the socket head screws to 90-100 inch-pounds or torque on DOA and DAA.

WARNING - The motor is thermally protected and can automatically restart when the protector resets. ALWAYS disconnect KES fan power source before servicing.

Do not attempt to replace the connecting rod or motor bearings. If after cleaning the unit and/or installing a new service kit, the unit still does not operate properly, contact your representative, the factory, or return the pump to one of our authorized Service Centers.

IF YOUR PUMP IS EQUIPPED WITH PLASTIC PLUGS IN THE EXHAUST AND/OR INTAKE POTS, REMOVE BEFORE STARTING THE UNIT

Wiring Information

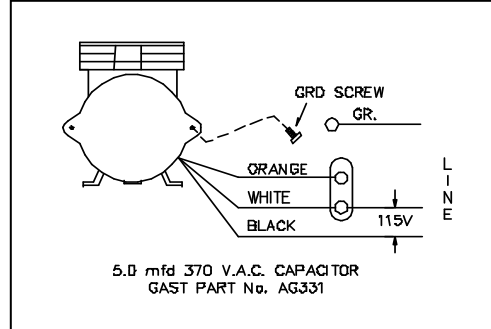
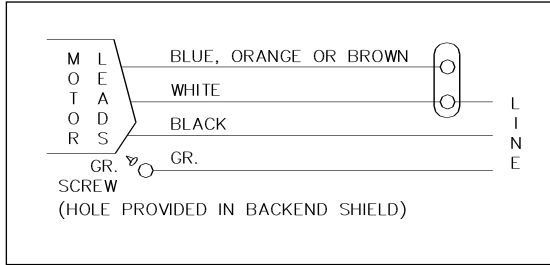

For any permanent split capacitor motor, which has four (4) leads is as follows:

Brown leads to capacitor. Black leads to Power Source.

For any permanent split capacitor for DOA & DAA motor, which has three (3) leads is as follows:

IMPORTANT NOTICE:

DO NOT AT ANY TIME ATTEMPT TO REMOVE THE CONNECTING ROD OR COMPLETELY DISASSEMBLE THE PUMP. IF IT DOES NOT GIVE YOU THE PROPER SERVICE EVEN AFTER INSTALLING A NEW SERVICE KIT, PLEASE RETURN IT TO ONE OF THE AUTHORIZED SERVICE CENTERS

WHERE TO PURCHASE FILTERS:

Spring Air Systems Inc.

1388 Cornwall Rd., Oakville Ont., L6J 7W5
(905) 338-2999

Airguard Industries

125 Buttermill Rd., Concord, Ontario, L4K 3X5
905-669-9876

Airguard Corp.

4806 Strong Rd., Crystal Lake, IL, 60014
888-324-5665

Camfil Farr Filters

67 Steelecase Rd. W., Markham Ont., L3R 2M4
(905) 415-3030

Camfil Farr

2201 Park Place, El Segundo, CA, 90245
310-727-6300

RECOMMENDATION

TO ENSURE TROUBLE FREE OPERATION FOR YOUR KITCHEN EXHAUST SYSTEM A PROPER PREVENTATIVE MAINTENANCE PROGRAM IS A NECESSITY.

SPRING AIR SYSTEMS RECOMMENDS THAT A YEARLY SERVICE CONTRACT BE SET UP WITH A REPUTABLE SERVICE ORGANIZATION. THIS WILL REDUCE UNEXPECTED DOWN TIME TO A MINIMUM.

REPLACEMENT FILTER EQUIVALENTS

PREFILTERS: 30% ASHRAE 52-76 - ULC Class II

Airguard: 24" x 24" x 2" - DP40 Class II
12" x 24" x 2" - DP40 Class II
American Air Filter:
24" x 24" x 2" - AM-AIR Class II
12" x 24" x 2" - AM-AIR Class II
Farr Filters: 24" x 24" x 2" - 30% ASHRAE 52-76 Class II
12" x 24" x 2" - 30% ASHRAE 52-76 Class II

BAG FILTERS: 90 - 95% ASHRAE 52 - 76 - ULC Class II

Airguard: 24" x 24" x 22" - V9-4M Class II
12" x 24" x 22" - V9-4M Class II
American Air Filter:
24" x 24" x 21" - DRI-PAK - Class II
12" x 24" x 21" - DRI-PAK - Class II
Farr Filters: 24" x 24" x 22" - 90% ASHRAE 52-76 Class II
12" x 24" x 22" - 90% ASHRAE 52-76 Class II

BOX FILTERS: 95% DOP/99% ASHRAE 52-76 ULC Class II

Airguard: 24" x 24" x 12" - VMB- 904 Class II
12" x 24" x 12" - VMB-904 Class II
American Air Filter:
24" x 24" x 12" - BIOCELL Class II
12" x 24" x 12" - BIOCELL Class II
Farr Filter:
24" x 24" x 12" - 6 pocket - 95% DOP Class II
12" x 24" x 12" - 6 pocket - 95% DOP Class II

ODOR MEDIA: 1/8" Activated alumina pellets impregnated with potassium permanganate.

Airguard: Barneby-Cheney CP-2
American Air Filter: Permasorb
Farr Filters: Unisorb.
Odor Spray: Spring Fresh, Spring Air Systems

WHEN TO CHANGE THE KES FILTERS

The Prefilter, Bag filter and Box filter must be changed on a regular basis to maintain the high grease extraction efficiency required by the UL/ULC listing. Once a filter clogged light comes on the filter has reached its grease holding capacity. Further use will restrict exhaust air flow causing hood smoke capture problems and/or cause the clogged filter to blow out into the next filter or the exhaust fan. Therefore the three particulate filters must be changed before the Filter Clogged lights activate and shut the unit down under normal kitchen operation. This will provide simple uninterrupted operation for your commercial kitchen operation.

Determine the Filter Change Schedule

When the KES unit is turned over to you by the installing contractor immediately change the Prefilters. The Prefilters will probably be full of construction debris and this debris will effect the initial operation of the unit.

PREFILTERS

1. Enter the startup date on the attached FILTER FREQUENCY CHART. This is the date the Prefilters were changed as well.
2. Run the unit until the Prefilter Clogged lights turns on. When the light comes on the unit will shut down. Immediately turn the Override switch clockwise and put the unit into override. The unit will come back on. Change the prefilters at the end of the shift or the next day before cooking. Write the date that the Prefilters were changed on the FILTER REQUENCY CHART under Filter Change No. 1/Actual.
3. Determine the number of days between the Startup date and the Prefilter Change No. Actual date. Subtract two days from this number. Add the this number of days to the last actual prefilter change and enter this new prefilter schedule date in the schedule under Filter Change No. 2/Schedule. Change the Prefilters on this new date. If the Filter light activates before this new date reduce the number of days to the next scheduled change by one day.

BAG FILTERS

1. Run the unit until the Bag Filter Clogged lights turns on. When the light comes on the unit will shut down. Immediately turn the Override switch clockwise and put the unit into override. The unit will come back on. Change the Bag filters at the end of the shift or the next day before cooking. Write the date that the Bag filters were changed on the FILTER REQUENCY CHART under Filter Change No. 1/Actual.
2. Determine the number of days between the Startup date and the Bag filter Change No. Actual date. Subtract two days from this number. Add the this number of days to the last actual bag filter change and enter this new bag filter schedule date in the schedule under Filter Change No. 2/Schedule. Change the bag filters on this new date. If the Filter light activates before this new date reduce the number of days to the next scheduled change by one day.

BOX FILTERS

1. Run the unit until the Box Filter Clogged lights turns on. When the light comes on the unit will shut down. Immediately turn the Override switch clockwise and put the unit into override. The unit will come back on. Change the Box filters at the end of the shift or the next day before cooking. Write the date that the Box filters were changed on the FILTER REQUENCY CHART under Filter Change No. 1/Actual.
2. Determine the number of days between the Startup date and the Box filter Change No. Actual date. Subtract two days from this number. Add the this number of days to the last actual box filter change and enter this new box filter schedule date in the schedule under Filter Change No. 2/Schedule. Change the box filters on this new date. If the Filter light activates before this new date reduce the number of days to the next scheduled change by one day.

By following the above procedure you will maximize your filter life. Changing the prefilter prior to clogging improves the bag filter life and changing the bag filter prior to clogging improves the box filter life.

**LACK OF EXHAUST VOLUME PRIOR TO SCHEDULED FILTER CHANGE
(IF YOU HAVE A MXFLOW OPTION ON YOUR KESF SKIP THIS SECTION)**

When all the filters are clean the exhaust volume is at the maximum. Each of the three filters captures various size grease particulate. The Prefilter capturing the very largest and the Box filter the very smallest. In very heavy applications with large quantities of both micron and submicron particles the exhaust air volume will reduce as the filters clog. If the loading is too heavy the FILTER OUT light will activate. This means that either someone has removed a filter or the exhaust air volume has reduced to a dangerous level. Immediately change the Prefilter. If this does not clear the FILTER REMOVED annunciation change the BAG Filter. Reschedule the next filter changed based on this new period of time.

Similarly should you experience lack of smoke capture during operation of your hood system prior to a scheduled filter change immediately change the Prefilter. If this does not clear the problem change the BAG Filter. If this does not clear the problem put the old Prefilter and Bag Filters in the unit replace the Box Filter. If this does not clear the problem replace the Prefilter and Bag Filters. Reschedule the next filter changed based on this new period of time.

| FILTER FREQUENCY CHART | | | | | | |
|-------------------------------------|-----------|--------|------------|--------|------------|--------|
| Startup date/First Prefilter change | | | | | | |
| Change No. | Prefilter | | Bag Filter | | Box Filter | |
| | Schedule | Actual | Schedule | Actual | Schedule | Actual |
| 1 | | | | | | |
| 2 | | | | | | |
| 3 | | | | | | |
| 4 | | | | | | |
| 5 | | | | | | |
| 6 | | | | | | |
| 7 | | | | | | |
| 8 | | | | | | |
| 9 | | | | | | |
| 10 | | | | | | |
| 11 | | | | | | |
| 12 | | | | | | |
| 13 | | | | | | |
| 14 | | | | | | |
| 15 | | | | | | |
| 16 | | | | | | |
| 17 | | | | | | |
| 18 | | | | | | |
| 19 | | | | | | |
| 20 | | | | | | |
| 21 | | | | | | |
| 22 | | | | | | |
| 23 | | | | | | |
| 24 | | | | | | |

TROUBLE SHOOTING

I. Exhaust fan does not run.

Reset the system once. Press the reset button in the LV10 J-Box or turn the fan selector switch to "OFF" and "ON". Observe the sequence that follows.

1.The fan does not start and there is no indication on remote panel.

- a)Check power from the breaker to the RPD-KW panel.
- b)Check the three wiring connection from the wash panel to the RPD-KW panel.

2.The fan does not start but the green normal pilot energizes for 30 seconds goes out and "Filter removed" pilot energizes.

- a)Check wiring between KES filter box LV10 J-box terminals 5 & 4 and the KESF fan motor starter.
- b)Check wiring between the RPD10 or RPW10 remote and the KES-ISH LV10 J-Box
- c)Reset the exhaust fan overload in the exhaust fan motor starter on the KESF fan section.
- d)Check three phase power to the KESF fan section disconnect.
- e)Check if exhaust duct access door is open between the KES filter section and hood.
- f)Check that all filters on in place.
- g)Check if the prefilter or box filter access door on the KES unit is open
- h)Check the Filter Removed alarm settings on logo in RPD. The switch must make and close after 30 seconds of operation. Adjust the pressure setting or replace transducer.
- i)If all the filters are in place check if pressure tips on the end of the pressure switch manifolds are plugged. There is a pressure tip in front and behind each filter.
- j)Measure Exhaust air volume. If low increase fan RPM to within FLA of fan motor
- k)Check KESF exhaust fan motor starter coil. Replace or repair.
- l)Check KESF fan belts if loose or broken.
- m)Check KESF exhaust fan motor. Replace or repair.

3.The exhaust fan runs for 30 seconds then shuts off and one of the Filter Clogged pilots energizes.

- a.Check the wiring from the LV10-J-Box to the pressure transducer
- b.Check pressure transducer operation on P1, P2 & Ps on logo in RPD. Ax vales should be flashing changes in value. If not, check transducer terminals for MA readings. If MA signal is present at transducer, check wiring at terminals and re-check cat 5 cable.
- c.Check the wiring between the RPD10 or RPW10 panel and the LV10 J-Box.

II. Low Exhaust Air

1.Exhaust fan is running but exhaust air is low.

- a)Check if fan belts are slipping. Tighten if necessary.
- b)Check if fusible link fire damper has closed in the KES filter section. Replace fusible link.
- c)Check if filters are dirty but have not activated the "Filter Clogged" pilot. Replace dirty filters.

d)Check for correct fan rotation. To correct fan rotation switch two of the high voltage wires motor starter load sider or at the motor disconnect.

III. Filter Clogged Pilot On.

- 1.Filter clogged pilot indicates which filter section has plugged. Replace filter and reset system.
2. If the filter clogged activates earlier then the normal established schedule reset the pressure switches. If the kitchen usage or product has not changed, reset the pressure transducer alarms to slightly higher limits for clog on and clog off allowing 25 points difference. Pre-filter clog should be on 1.25 off 1.00 bag. Filter clog should be on 1.75 off 1.50. Box filter clog should be on 2.50 off 2.25.

IV. Filter Removed Pilot On.

- 1.A filter has been removed or access door left open. Replace if necessary.

V. Fire Pilot On.

- 1.The fire stat in the KES filter section exhaust outlet has activated and shut the KES system down. If a fire is not present check calibration of firestat TH1. Firestat should be set at 160F (105C).

If operation problems persist check the individual the connection between the RPD10 or RPW10 panel and the LV10 J-Box. If problems still exist contact an authorized SPRING AIR SYSTEMS service technician.

KES MAINTENANCE SCHEDULE

Every two weeks: See “When to Change Filter Section”

1. Inspect the prefilters. Replace if necessary. It is important to maintain clean prefilters. Replacing the inexpensive prefilters often extends the life of the bag and box filters and reduces unnecessary down time due to clogged filter shutdowns. *The RPD or RPW annunciation panel will indicate separately when the “prefilter”, “bag” and “box” filters are clogged. When this occurs the unit shuts down. Rotate the override switch to energize the system for about 4 hours. This provides time to change the filters after the day of cooking. This is a final dirty filter warning. The filter life of all the filters is constant for each operation. Once the approximate filter life for your application is determined we recommend that a regular filter change schedule be set up before the filter out switches activate.*

Every Month: “When to Change Filter Section”

1. Complete the two-week list.
2. Inspect the exhaust fan belt for correct tension and wear. All belts usually require adjustment at this time. Failure to tighten may result in the belt falling off and no airflow.
3. Inspect the bag filters (2nd stage filtration). Replace if necessary. The life of the bag filter depends on the type of cooking equipment and exhaust hood system. For heavy cooking applications the bag filters may require replacement every month.
4. **(Odor Spray Option)** Inspect the odor spray bottle. Refill if necessary. *At startup the odor spray is adjusted to the desired level. The amount of odor spray used varies with this initial setting. It is important to inspect the level in the bottle every two weeks until the normal rate of use is determined.*

Every Three Months: “When to Change Filter Section”

1. Complete the two-week and monthly checklist.
2. Inspect the exhaust fan belt for correct tension and wear. Adjust if necessary.
3. Inspect the box filters (3rd stage filtration). Replace if necessary. Once again the life of the box filter depends on the type of cooking equipment and exhaust hood system. The box filter may provide one year of service on most applications with high efficiency water wash ventilators.
4. Inspect all electrical connections. Tighten if necessary.
5. Test the filter-removed circuit. Open the prefilter access door while the KES unit is in operation. The unit should shut down and indicate a filter-removed condition.

Every Six Months “When to Change Filter Section”

1. Complete the two-week, monthly and three month check list.
2. Open the fan wheel access door or hatch on the KES fan section. Inspect the fan wheel for grease build up. Clean as required.
3. Inspect the exhaust inlet fire damper and fusible link. Replace link annually.
4. Check the motor and fan bearings for noise or overheating.
5. **(Odor Pellet Option)** Inspect the condition of odor media.
6. *The odor media pellets can be checked for remaining life by sending a sample to an accredited test laboratory. Most major filter suppliers have access to such service. Replace media if required. To replace the media remove the cells from the KES unit. Open the side panel on each odor cell and pour out the used media. Refill the cells with new media. Shake cells while filling to allow pellets to settle evenly in the cell. **Note:** Do not allow odor media to come in contact with water, as this will immediately render the pellets useless.*

Fan Bearings

1. STY and FYC bearings are factory pre-lubricated lifetime sealed and require no further lubrication.
2. SY and FY bearings are pre-lubricated and equipped with pressure grease fittings for re-greasing.
3. Under normal service conditions grease after six months of operation.

Motor Bearings:

1. All motors leave the factory with bearings custom greased for many years of service under most conditions.
2. Re-greasing of motors depends on the application and is best left to trained service technicians.
3. Periodically check if motor is running hotter than normal.

Centrifugal Exhaust Fan:

1. Make sure the wheel rotates freely before startup.
2. Inspect and clean the wheel periodically.
3. If dirt is allowed to build up the wheel could become out of balance and cause premature bearing wear.
4. A noisy fan is a typical sign of a fan out of balance.

V-Belt Drives:

1. ALWAYS KEEP SPARE SET OF BELTS. Periodically check the belt tension and adjust if necessary.
2. Some slack should be left in the belt, typically 1/4" per foot of belt from the fan to the motor sheave.
3. Always replace the complete set of belts to ensure even tension and wear. When replacing belts loosen the motor mounts.
4. Do not force belts over sheaves.

RECOMMENDATION

TO ENSURE TROUBLE FREE OPERATION FOR YOUR KITCHEN EXHAUST SYSTEM A PROPER PREVENTATIVE MAINTENANCE PROGRAM IS NECESSARY. SPRING AIR RECOMMENDS THAT A YEARLY SERVICE CONTRACT BE SET UP WITH A REPUTABLE SERVICE ORGANIZATION. THIS WILL REDUCE UNEXPECTED DOWN TIME TO A MINIMUM.

PROGRAMMING THE SMART CLOCK

Setting the Day and Time

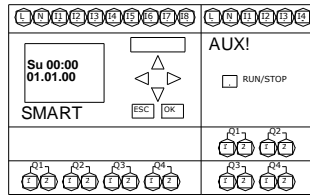

- | | |
|---|--|
| Su 00:00 01.01.00 | 1. When power is first applied to the RPD10 panel the following display will blink. If the SERVICE FILTERS WITHIN 4 HOURS displays instead the OVERRIDE switch is on. Just rotate the switch and the correct display will blink. |
| >Stop Set Parma Set Clock Prg Name | 2. Press OK and the following screen will appear. |
| Stop Set Parma >Set Clock Prg Name | 3. Press ▽ twice. |
| Set Clock Su 00:00 MM.DD.YY 01. 01. 00 | 4. Press OK and the following screen will appear. |
| Set Clock Th 00:00 MM.DD.YY 01. 01. 00 | 5. To change the day press △ until the correct day appears. |
| Set Clock Th 00:00 MM.DD.YY 01. 01. 00 | 6. To change the time press ▷ once. The hour will be highlighted. Press △ or ▽ until the correct hour appears. Press ▷ to move to minutes. Adjust the minutes by pressing △ or ▽ until correct minutes appears. |
| Set Clock Su 06:16 MM.DD.YY 01. 01. 00 | 7. To change the date press ▷ again. The month will be highlighted. Press △ or ▽ until the correct month appears. Press ▷ to move to day. Adjust the day by pressing △ or ▽ until correct day appear. Press ▷ to move to year. Adjust the year by pressing △ or ▽ until correct year appears. |
| Set Clock Su 06:16 MM.DD.YY 01. 06. 03 | 8. You have finished setting the clock. |
| Su 06:16 01. 06. 03 | 7. Press OK and ESC to return to the operating screen. |

Setting the clock on RPD10A automatic panels
Figure 19

Setting the Weekend Fan "ON" and "OFF" times

| | |
|--|--|
| Su 06:16 01. 06. 03 | 1. Press <input type="button" value="ESC"/> |
| >Stop Set Parma Set Clock Prg Name | 2. Press <input type="button" value="▽"/> once. |
| Stop >Set Parma Set Clock Prg Name | 3. Press <input type="button" value="OK"/> |
| B04: No1 D =MTWTFSS On = 06: 00 Off = 23: 00 | 4. Press <input type="button" value="△"/> until the B04: No1 timer appears. This is the time setting for start and stop each weekday. |
| B04: No1 D =MTWTFSS On = 06: 00 Off = 23: 00 | 5. The clock has been factory set to turn the fan on at 6:00 a.m. and off at 23:00 hours or 11:00 p.m. |
| B04: No1 D =■TWTFSS On = 06: 00 Off = 23: 00 | 6. To change the above settings press <input type="button" value="OK"/> The cursor will move to M = Monday. |
| B04: No1 D = MTWTF-S On = 06: 00 Off = 23: 00 | 7. Press <input type="button" value="△"/> to remove Monday from the weekly schedule. The - dash indicates the fan will not start automatically any given day. |
| B04: No1 D = - TWTF- - On = 06: 00 Off = 23: 00 | 8. Press <input type="button" value="▷"/> to move to the next day of the week. Press <input type="button" value="△"/> each time the fan is not required to operate on that given day. The screen on the left indicates the fan will not automatically operate on Monday, Saturday or Sunday. |
| B04: No1 D = - TWTF- - On = ■6: 00 Off = 23: 00 | 9. Press <input type="button" value="▷"/> to move to the hour that the fan will start in the morning. Press <input type="button" value="▷"/> to change the hour you want the fan to start in each morning. Press <input type="button" value="▷"/> to move to the minute the the fan will start in the morning. Press <input type="button" value="△"/> to change the minutes. |
| B04: No1 D = - TWTF- - On = 06: 30 Off = ■3: 00 | 10. Press <input type="button" value="▷"/> to move to the hour that the fan will stop in the evening. Press <input type="button" value="▷"/> to change the hour you want the fan to stop each evening. Press <input type="button" value="▷"/> to move to the minute the fan stop in the evening. Press <input type="button" value="△"/> to change the minutes. |
| B04: No1 D = MTWTF- - On = 06: 30 Off = 22: 30 | 11. Press <input type="button" value="OK"/> |
| Su 06:16 01. 06. 03 | 12. If your selection is complete press <input type="button" value="ESC"/> and <input type="button" value="ESC"/> to return to the operating screen. You have completed programming one weekly fan "On" and "Off" cycling. If you wish to program a second (Weekend Operation) or third weekly setting go the the section "Setting Weekend Operation" |

*Setting the Week Day Fan On and Off Timers on RPD10A automatic panels
Figure 20*

Setting Weekend Operation

| | |
|---|--|
| <p>Su 06:16 01. 06. 03</p> | 1. Press <input type="button" value="ESC"/> |
| <p>>Stop Set Parma Set Clock Prg Name</p> | 2. Press <input type="button" value="▽"/> once. |
| <p>Stop >Set Parma Set Clock Prg Name</p> | 3. Press <input type="button" value="OK"/> |
| <p>B04: No2 D = - - - - - On = - - : - - Off = - - : - -</p> | 4. Press <input type="button" value="△"/> until the B04: No1 timer appears. This is the time setting for start and stop each weekday. |
| <p>B04: No2 D = ■ - - - - - On = - - : - - Off = - - : - -</p> | 5. Press <input type="button" value="OK"/> to program the weekend operation. |
| <p>B04: No2 D = - - - - - SS On = - - : - - Off = - - : - -</p> | 6. Press <input type="button" value="▷"/> five times to move to Saturday. Press <input type="button" value="△"/> to turn fan on Saturday. Press <input type="button" value="▷"/> once to move to Sunday. Press <input type="button" value="△"/> to turn fan on Sunday. |
| <p>B04: No2 D = - - - - - SS On = ■ - - : - - Off = - - : - -</p> | 7. Press <input type="button" value="▷"/> to move to the hour that the fan will start in the morning. Press <input type="button" value="△"/> to change the hour you want the fan to start in each morning. Press <input type="button" value="▷"/> to move to the minute the the fan will start in the morning. Press <input type="button" value="△"/> to change the minutes. |
| <p>B04: No2 D = - - - - - SS On = 10: 00 Off = ■ - : - -</p> | 8. Press <input type="button" value="▷"/> to move to the hour that the fan will stop in the evening. Press <input type="button" value="△"/> to change the hour you want the fan to stop each evening. Press <input type="button" value="▷"/> to move to the minute the fan stop in the evening. Press <input type="button" value="△"/> to change the minutes. |
| <p>B04: No2 D = - - - - - SS On = 10: 00 Off = 23: 30</p> | 9. Press <input type="button" value="OK"/> If your selection is complete press <input type="button" value="ESC"/> and <input type="button" value="ESC"/> to return the operating screen. |
| <p>Su 06:16 01. 06. 03</p> | 10. You have completed programming weekend fan "On" and "Off" cycling. |

*Setting the and Weekend Fan On and Off Timers on RPD10A automatic panels
Figure 21*

SETTING THE FILTER OUT LIMITS AT STARTUP

The Filter OUT PCL setting for each KES unit may have to be adjusted during startup because each commercial kitchen exhaust system total pressure is not the same. The Filter Out (PRE OFF, BAG OFF and BOX OFF) settings must be adjusted below the current pressure reading (Ax) for the Pre-filter, Bag Filter and Box Filter transmitter in the LV20 RPD. All functions are controlled by the PLC located in the RPD-KD or RPD-KW remote panel located in the kitchen area. The LV10 PLC interlocks to the RPD-KD or RPD-KW panel.

Note: Only the Filter Out limits for Pre-Filter (PRE O), Bag (BAG O) and Box (BOX O) filters must be checked at startup. The Filter Clogged limits are factory preset for the factory supplied filters.

The P1 (Pre-filter), and P2 (Bag Filter) transmitters send a 4-20 ma signal to the Auxiliary 1 module attached to the PLC. The P3 (Box Filter) transmitter signals a 4-20 ma signal to the Auxiliary 2 module located next to Auxiliary 1 module. The PLC converts the 4-20 milliamp signals to a static pressure value.

GETTING STARTED

Turn on the KES. Override the KES unit. The override switch is found on the remote RPD-KD or RPD-KW. When the KES is in override an amber pilot light on the RPD-KD or RPDW-KW will flash.

Open the RPD panel located in the kitchen. Proceed with caution as the panel is powered. When looking at the PLC screen in the LV10 for the first time it displays the date and time as shown in Figure 35. This is the main screen which serves as the basis for the following steps. If date and time is incorrect, refer to “setting the day and time” segment at the beginning of programming the logo.

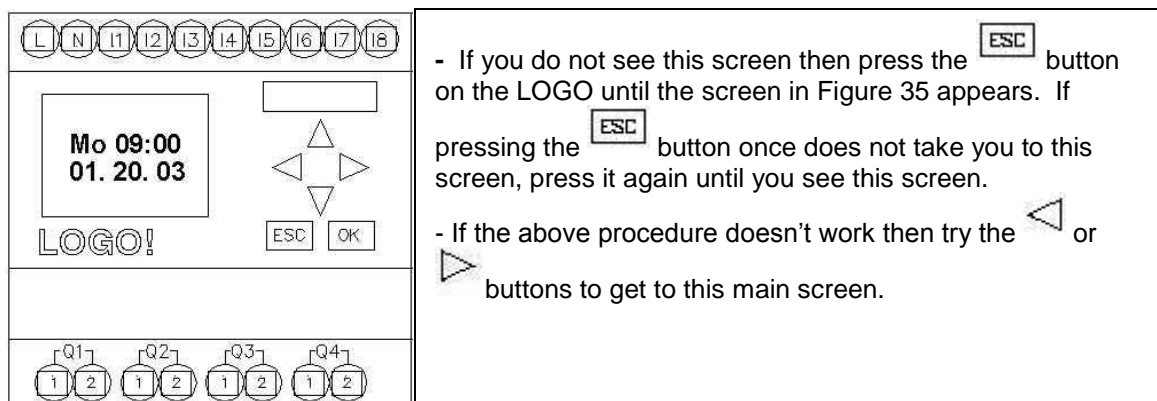

Figure 22

VIEWING THE PARAMETERS

To set any parameter you must be on the Main Screen in Figure 35 to continue.

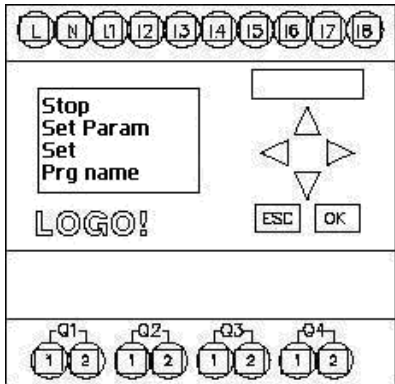

Figure 23

- Press the button to show the screen in Figure 36. Press the button to select "Set Param" option and press .
- Press the button twice to proceed to the screen in Figure 37

FILTER OUT PARAMETERS

The limits for the filter out are factory preset for each filter. You must verify that these limits are correct when the filter out does not activate properly. The Ax variable on each screen is the current pressure reading through the filter section. The current reading (Ax) must be higher than the "Off" limit setting for that filter. This limit determines whether the filter is out. To check if the off limit is correct take the filter out. You will see a screen on the PLC displaying the static pressure the filter out occurred and the filter out pilot light on the RPD-K will turn on. Put the filter back in. This has to be done for each type of filter individually in the KES.

Note: The values you set in the PLC MUST BE 100 times the actual static pressure. For example if you want the actual pressure limit to be 0.35" W.C., you need to input 35 in the PLC.

SETTING PRE-FILTER OUT (PRE O)

Factory Presets

On = -10

Off = 5

Ax = Current reading through this filter section with filter still in.

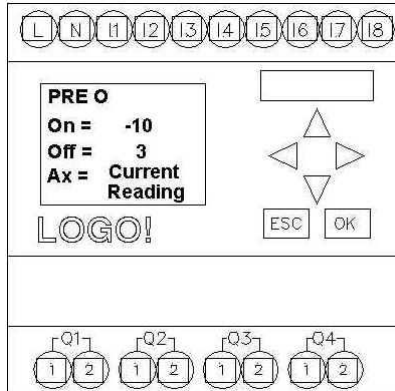

Figure 24

- Press the button to get into the editor and then use the & buttons to navigate and & buttons to change values.
- Press the button to save your changes.
- Press the button twice to proceed to the next screen in Figure 38.

SETTING BAG-FILTER OUT (BAG O)

Factory Presets

On = -10

Off = 5

Ax = Current reading through this filter section with filter still in.

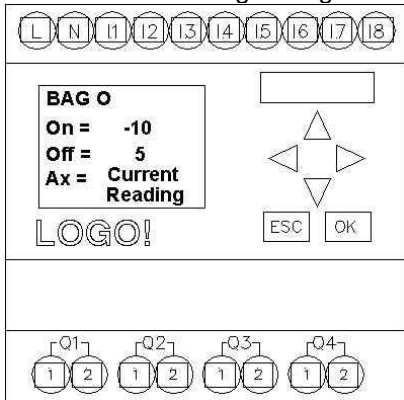

- Press the button to get into the editor and then use the & buttons to navigate and & buttons to change values.
- Press the button to save your changes.
- Press the button twice to proceed to the next screen in Figure 39.

Figure 25

SETTING BOX-FILTER OUT (BOX O)

Factory Presets

On = -10

Off = 5

Ax = Current reading through this filter section with filter still in.

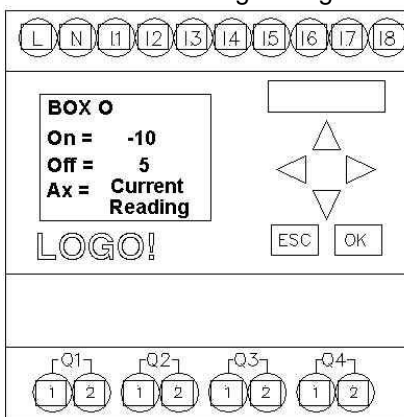

- Press the button to get into the editor and then use the & buttons to navigate and & buttons to change values.
- Press the button to save your changes.
- After finishing the setup press the button twice to get to the main screen in Figure 40.

Figure 26

Note: There is a 5 second delay before the filter out or clogged is triggered.

SETTING THE FILTER CLOGGED

The limits for the filter clogged settings are factory preset. These settings are the filter manufacturer recommended pressure limit at which the filters no longer continue operate efficiently. If you are replacing filters with an alternative manufacturer make sure you enter the new manufacturers pressure limits.

To change the filter clogged parameters go to screen in Figure 40 by following steps shown at the beginning of filter out setting section.

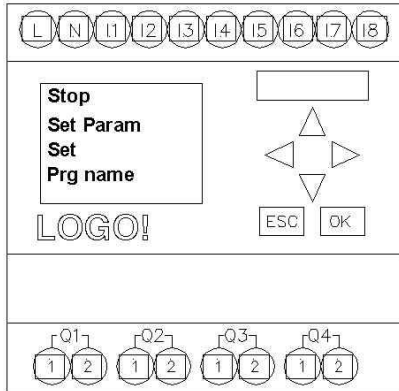



Figure 27

- Press the  button to select "Set Param" option and press .
- You will see screen shown in Figure 41.

SETTING THE PRE-FILTER CLOGGED

Factory Presets

On = 125

Off = 75

Ax = Current reading through this filter section with filter still in.

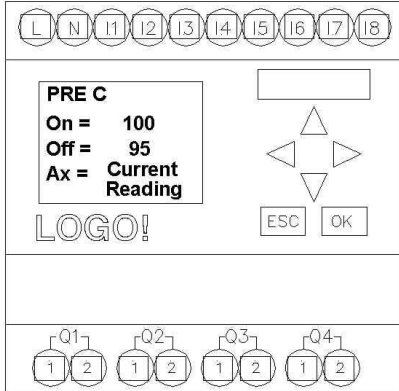









Figure 28

- Press the  button and then use the  &  buttons to navigate and  &  buttons to change values.
- Press the  button to save your changes.
- Press the  button twice to proceed to the next screen in Figure 42

SETTING THE BAG-FILTER CLOGGED

Factory Presets

On = 175

Off = 150

Ax = Current reading through this filter section with filter still in.

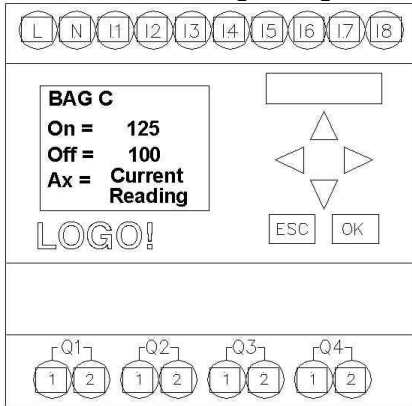

- Press the button to and then use the & buttons to navigate and & buttons to change values.
- Press the button to save your changes.
- Press the button twice to proceed to the next screen in Figure 43

Figure 29

SETTING THE BOX-FILTER CLOGGED

Factory Presets

On = 250

Off = 225

Ax = Current reading through this filter section with filter still in.

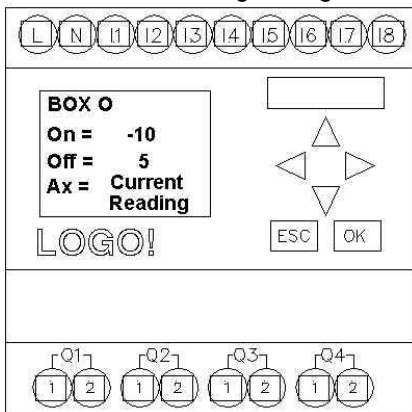

- Press the button to get into the editor and then use the & buttons to navigate and & buttons to change values.
- Press the button to save your changes.
- After finishing the setup press the button twice to get to the main screen in Figure 35

Figure 29

APPENDIX

A. VFD ONLY:

FACTORY DRIVE TERMINAL SCHEMATIC

Wiring Diagram for Factory Settings

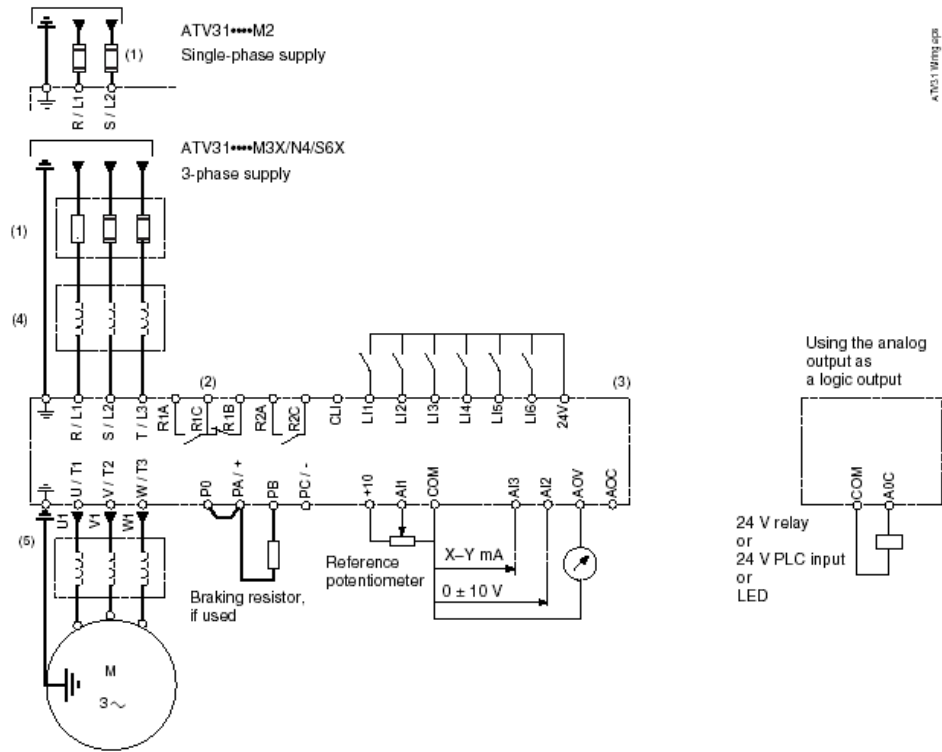

NOTE: The line supply terminals are shown at the top and the motor terminals are shown at the bottom. Connect the power terminals before connecting the control terminals. Install surge suppressors on all inductive circuits located near the drive controller or coupled to the same circuit.

- (1) Refer to the drive controller nameplate or to the tables on pages 34–35 for recommended fuses. Fast acting or time delay Class J fuses can be used.
- (2) Fault relay contacts for remote indication of drive controller status.
- (3) Internal +24 V. If an external source is used (30 V max.), connect the 0 V terminal of the source to the 0 V (COM) terminal, and do not use the +24 V terminal on the drive controller for any purpose.
- (4) Line reactor, if used. All 575 V installations must include a line reactor. See page 21.
- (5) Installation of a load filter is recommended for all 575 V applications. See page 22.

LOGIC INPUT SWITCH

The logic input switch assigns the logic input common link to 0 V (Source logic), 24 V (Sink logic), or floating.

NOTE: When the logic input is configured for Sink logic, grounding the input signals can result in unintended activation of drive controller functions.

⚠ DANGER

UNINTENDED EQUIPMENT OPERATION

- Protect the signal conductors against damage that could result in unintentional conductor grounding.
- Follow NFPA 79 and EN 60204 guidelines for proper control circuit grounding practices.

Failure to follow these instructions can result in death, serious injury, or equipment damage.

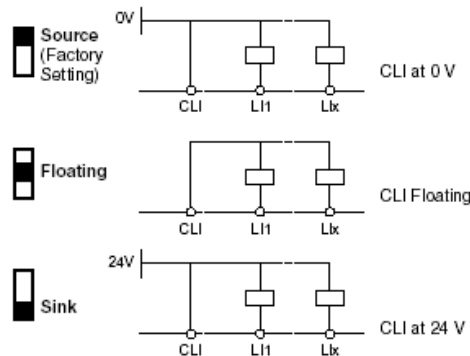

KV051 Logic Input Switch.rxp

DRIVE TECHNICAL SPECIFICATIONS FOR LOCATING DRIVE PANELS

Table 2: Environment

| | |
|-----------------------------|---|
| Degree of Protection | <ul style="list-style-type: none"> • IP20 without protective vent cover, NEMA 1, UL open type. • IP21 on wiring terminals • IP31 and IP41 all other areas • UL Type 1 without removal of the protective vent cover from the top of the controller and with the addition of the Conduit Entry Kit (see page 14). |
| Resistance to vibrations | Conforming to IEC/EN 60068-2-6: 1.5 mm peak to peak from 3 to 13 Hz, 1 gn from 13 to 150 Hz |
| Resistance to shocks | 15 gn for 11 ms conforming to IEC/EN 60068-2-27 |
| Pollution degree | Pollution degree 2 according to UL 840. Protect the drive controller against dust, corrosive gas, and falling liquid. |
| Maximum relative humidity | 96% maximum, non-condensing and without dripping (provide heating system if there is condensation) Conforms to IEC 60068-2-3 |
| Maximum ambient temperature | Storage: -13 to +158 °F (-25 to +70 °C) Operation: +14 to +122 °F (-10 to +50 °C) without vent cover removed and without derating +14 to +140 °F (-10 to +60 °C) with vent cover removed and with derating. Refer to derating curves on page 15. |
| Altitude | Up to 3,300 ft (1,000 m) without derating; derate by 1% for each additional 330 ft (100 m) |

B. HAZARDOUS WARNING

 DANGER

HAZARDOUS VOLTAGE

- Read and understand this manual before installing or operating the Altivar 31 drive controller. Installation, adjustment, repair, and maintenance must be performed by qualified personnel.
- For more information on Altivar 31 drive controllers, see the *Altivar 31 Start-Up Guide*, VVDED303043US, and the *Altivar 31 Programming Manual*, VVDED303042US. Both manuals are shipped with the drive controller. They are also available from www.us.SquareD.com or from your Schneider Electric representative.
- The user is responsible for conforming to all applicable code requirements with respect to grounding all equipment.
- Many parts in this drive controller, including printed wiring boards, operate at line voltage. **DO NOT TOUCH.** Use only electrically insulated tools.
- **DO NOT** touch unshielded components or terminal strip screw connections with voltage present.
- **DO NOT** short across terminals PA and PC or across the DC bus capacitors.
- Install and close all covers before applying power or starting and stopping the drive controller.
- Before servicing the drive controller:
 - Disconnect all power.
 - Place a "DO NOT TURN ON" label on the drive controller disconnect.
 - Lock the disconnect in the open position.
- Disconnect all power including external control power that may be present before servicing the drive controller. **WAIT 3 MINUTES** for the DC bus capacitors to discharge. Then follow the DC bus voltage measurement procedure on page 20 to verify that the DC voltage is less than 45 Vdc. The drive controller LEDs are not accurate indicators of the absence of DC bus voltage.

Electric shock will result in death or serious injury.

C. VFD ONLY: GOOD WIRING PRACTICE

Good wiring practice requires the separation of control circuit wiring from all power (line) wiring. In addition, power wiring to the motor must have the maximum possible separation from all other power wiring, whether from the same drive controller or other drive controllers; **do not run in the same conduit**. This separation reduces the possibility of coupling electrical transients from power circuits into control circuits or from motor power wiring into other power circuits.

| ▲ CAUTION |
|--|
| <p>IMPROPER WIRING PRACTICES</p> <ul style="list-style-type: none">• Follow the wiring practices described in this document in addition to those already required by the National Electrical Code and local electrical codes.• The drive controller will be damaged if input line voltage is applied to the output terminals (U, V, W).• Check the power connections before energizing the drive controller.• If replacing another drive controller, verify that all wiring connections to the ATV31 drive controller comply with all wiring instructions in this manual. <p>Failure to follow this instruction can result in injury or equipment damage.</p> |

Follow the practices below when wiring ATV31 drive controllers:

- Verify that the voltage and frequency of the input supply line and the voltage, frequency, and current of the motor match the rating on the drive controller nameplate.
 - Use metallic conduit for all drive controller wiring. Do not run control and power wiring in the same conduit.
 - Separate the metallic conduits carrying power wiring from those carrying control wiring by at least 76 mm (3 in.).
-
- Separate the non-metallic conduits or cable trays used to carry power wiring from the metallic conduit carrying control wiring by at least 305 mm (12 in.).
 - Whenever power and control wiring cross, the metallic conduits and non-metallic conduits or trays must cross at right angles.
 - Equip all inductive circuits near the drive controller (such as relays, contactors, and solenoid valves) with noise suppressors, or connect them to a separate circuit.

D. VFD ONLY: GROUNDING

Ground the drive controller according to the National Electrical Code and all local codes to ensure safe, dependable operation. To ground the drive controller:

- Connect a copper wire from the equipment ground lug or terminal to the power system ground conductor. Size the wire according to the drive controller rating and national and local codes.
- Verify that resistance to ground is one ohm or less. Improper grounding causes intermittent and unreliable operation.

⚠ DANGER

HAZARDOUS VOLTAGE

Ground equipment using the provided ground connecting point as shown in the figure below. The drive controller panel must be properly grounded before power is applied.

Electric shock will result in death or serious injury.

Ground multiple drive controllers as shown in the figure below. Do not loop the ground cables or connect them in series.

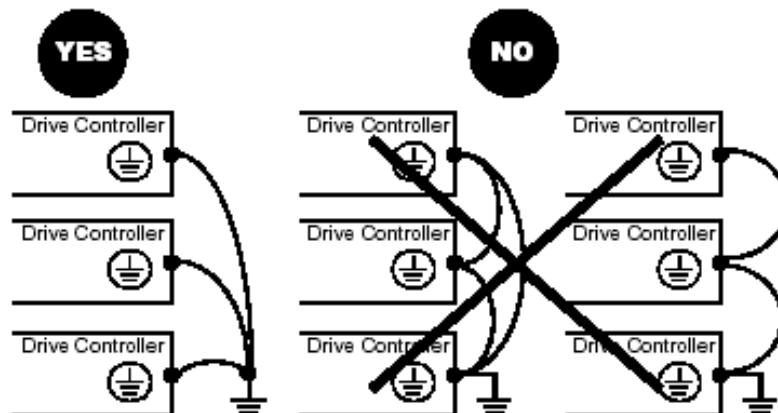

E. VFD ONLY: STARTING THE DRIVE

ATV31***** Controllers

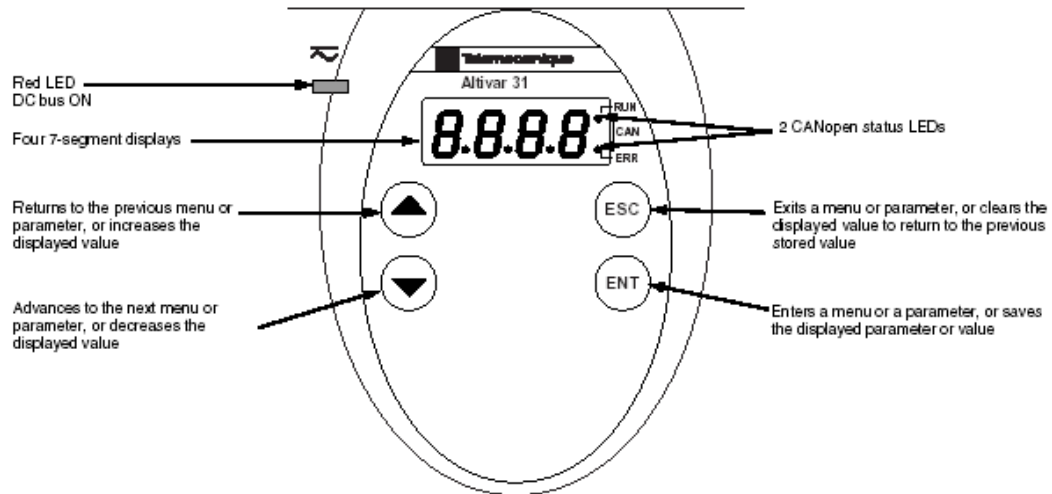

- Press and hold down (longer than 2 seconds) the ▲ or ▼ keys to scroll through the data quickly.
- Pressing ▲ or ▼ does not store the selection.
- To store the selection, press the ENT key. The display flashes when a value is stored.

A normal display with no fault present and no run command shows:

- The value of one of the display parameters (see page 80). The default display is motor frequency, for example 43.0. In current limiting mode, the display flashes.
- init: Initialization sequence
- rdY: Drive ready
- dcb: DC injection braking in progress
- nSt: Freewheel stop
- FSt: Fast stop
- tUn: Auto-tuning in progress

If a fault is present, the display flashes.

F. VFD ONLY: ACCESSING THE DRIVE PROGRAM MENU

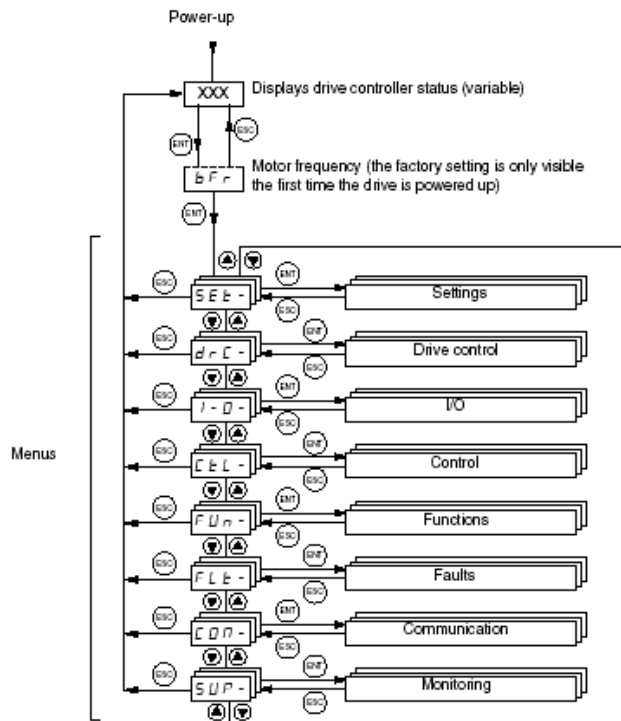

The following figure illustrates how to access parameters and assign their values. To store the parameter value, press the **MEM** key. The display flashes when a value is stored.

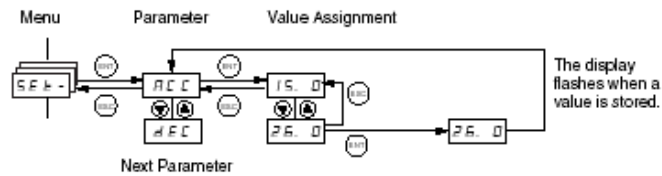

All of the menus are drop-down type menus. Once you have reached the last parameter in a list, press the **▼** key to return to the first parameter. From the first parameter in the list, press the **▲** key to jump to the last parameter.

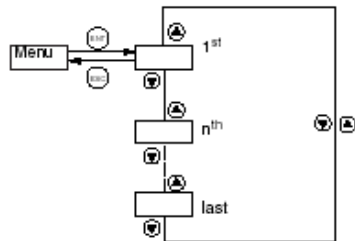

If you have modified a parameter in a menu and you return to that menu without accessing another menu in the meantime, you will be taken directly to the parameter you last modified. See the illustration below. If you have accessed another menu or have restarted the drive controller since the modification, you will be taken to the first parameter in the menu. See the illustration above.

G. VFD ONLY PROGRAMMING THE DRIVE PARAMETERS

MXFLOW Programming the variable speed Tele drive

| Code | Long Label | Factory Setting | Tele Default |
|-------------------------------|----------------------------|-------------------------------|-------------------------|
| Fast Settings | | | |
| ACC | Acceleration ramp time | 10.0s | 3.0s |
| BFR | Standard motor frequency | 60HZ | 50HZ |
| DEC | Deceleration ramp time | 10s | 3s |
| ITH | Motor thermal current | Motor FLA | 0.0A |
| **LSP | Low Speed | 50HZ | 0.0HZ |
| Motor Control | | | |
| NSP | Nominal Motor Speed | 1725 rpm of motor | 1715tr/min |
| TUN | Automatic Tuning | Autotune on Power up | Not Assigned |
| Terminal Configuration | | | |
| AOIT | Configuration of AOI | 4-20mA | 0-20mA |
| DO | AOC/AOV Assignment | Motor Frequency | Not Assigned |
| R1 | Relay R1 | Drive Running | Drive Fault |
| RRS | Reverse | Not Assigned | Logic Input LI2 |
| Control Command | | | |
| FR1 | Configuration reference 1 | Analog Input AI3 | Analog input AI1 |
| LAC | Function Access Level | Advance Function & Mixed ctrl | Access to Std. Function |
| Input Summary | | | |
| AI1A | Configuration of AI1 | CH. In forced local Mode | Configuration ref. 1 |
| AI2A | Configuration of AI2 | Not Assigned | Summing Input 2 |
| AI3A | Configuration of AI3 | Configuration ref. 1 | Not Assigned |
| LI2A | Config. Logic Input 2 | Select 2 Preset Speed | Reverse |
| LI3A | Config. Logic Input 3 | Select 3 Preset Speed | Select 3 Preset Speed |
| LI4A | Config. Logic Input 4 | Select 4 Reset Speed | Select 4 Preset Speed |
| Fault Behavior | | | |
| ATR | Automatic Restart | YES | NO |
| DRN | Derating for Undervoltage | YES | NO |
| Application Functions | | | |
| SA2 | Summing Input 2 | Not Assigned | Analog Input AI2 |
| SA3 | Summing Input 3 | Not Assigned | Not Assigned |
| SDC2 | DC Current at Standstill 2 | Motor Amp | 0.0A |
| SP2 | Preset Speed 2 | 60HZ | 10HZ |
| SP3 | Preset Speed 3 | 30 HX(optional) | 15HZ |
| SP4 | Preset Speed 4 | 50HZ (optional) | 20HZ |

Device Reference must be observed when programming
Parameter list based on ALTIVAR31
Motor Characteristics must be inputted (ie FLA, RPM)
Preset Speeds are adjustable.

H. VFD ONLY: TROUBLE SHOOTING AND DRIVE FAULT DISPLAY

PRECAUTIONS

Read the following safety statements before proceeding with any maintenance or troubleshooting procedures.

|  DANGER |
|---|
| HAZARDOUS VOLTAGE <ul style="list-style-type: none">• Disconnect all power before servicing the drive controller.• Read and understand these procedure and the precaution on page 13 of this manual before servicing the ATV31 drive controllers.• Installation, adjustment, and maintenance of these drive controllers must be performed by qualified personnel. Failure to follow this instruction will result in death or serious injury. |

ROUTINE MAINTENANCE

Perform the following steps at regular intervals:

- Check the condition and tightness of the connections.
- Make sure that the ventilation is effective and that the temperature around the drive controller remains at an acceptable level.
- Remove dust and debris from the drive controller, if necessary.

FAULT DISPLAY

If a problem arises during setup or operation, ensure that all ambient environment, mounting, and connection recommendations have been followed.

The first fault detected is stored and displayed, flashing, on the screen. The drive controller locks and the fault relay (RA-RC) contact opens, if it has been configured for this function.

Drive Controller Does Not Start, No Fault Displayed

If the drive controller will not start and there is no display indication, consider the following:

1. Check the power supply to the drive controller.
2. The assignment of the fast stop or freewheel stop functions prevents the drive controller from starting if the corresponding logic inputs are not powered up. In this case, the drive controller displays nSt in freewheel stop mode and FSt in fast mode. This is normal, since these functions are active at zero speed so that the drive controller will stop safely if there is a wire break.
3. Ensure that the run command inputs have been actuated in accordance with the chosen control mode (ICC parameter in the I-O- menu. See page 29).
4. If an input is assigned to the limit switch function and this input is at state 0, the drive controller can only be started by sending a command for the opposite direction (see page 72).
5. If the reference channel (page 37) or the control channel (page 38) is assigned to Modbus or CANopen, the drive controller displays nSt on power up and remains stopped until the communication bus sends a command.

TROUBLESHOOTING

Fault Display

If a problem occurs during setup or operation, ensure that all ambient environment, mounting, and connection recommendations have been followed.

The first fault detected is stored and displayed, flashing, on the screen. The drive controller locks and the fault relay (R1A-R1C or R2A-R2C) contact opens.

Drive Controller Does Not Start, No Display

If the drive controller will not start and there is no display indication, check the power supply to the drive controller. Refer to the *ATV31 Programming Manual* for more troubleshooting information.

Faults Which Cannot be Automatically Reset

Faults which cannot be automatically reset are listed in the table beginning on page 44. To clear these faults:

1. Remove power from the drive controller.
2. Wait for the display to go off completely.
3. Determine the cause of the fault and correct it.
4. Reapply power.

CrF, SOF, tnF, bLF, and OPF can also be reset remotely via a logic input (rSF parameter in the FLT- menu, see the *ATV31 Programming Manual*).

Faults Which Cannot be Automatically Reset

| Fault | Probable Cause | Remedy |
|---|---|---|
| <i>b L F</i> Brake sequence | Brake release current not reached | <ul style="list-style-type: none"> • Check the drive controller and motor connections. • Check the motor windings. • Check the lbr setting in the FUn-menu. Refer to the <i>ATV31 Programming Manual</i>. |
| <i>C r F</i> Precharge circuit fault | Precharge circuit damaged | <ul style="list-style-type: none"> • Reset the drive controller. • Replace the drive controller. |
| <i>I n F</i> Internal fault | <ul style="list-style-type: none"> • Internal fault • Internal connection fault | <ul style="list-style-type: none"> • Remove sources of electromagnetic interference. • Replace the drive controller. |
| <i>O C F</i> Overcurrent | <ul style="list-style-type: none"> • Incorrect parameter settings in the SEt- and drC- menus • Acceleration too rapid • Drive controller and/or motor undersized for load • Mechanical blockage | <ul style="list-style-type: none"> • Check the SEt- and drC- parameters. • Ensure that the size of the motor and drive controller is sufficient for the load. • Clear the mechanical blockage. |
| <i>S C F</i> Motor short circuit | <ul style="list-style-type: none"> • Short circuit or grounding at the drive controller output • Significant ground leakage current at the drive controller output if several motors are connected in parallel | <ul style="list-style-type: none"> • Check the cables connecting the drive controller to the motor, and check the motor insulation. • Reduce the switching frequency. • Connect output filters in series with the motor. |
| <i>S O F</i> Overspeed | <ul style="list-style-type: none"> • Instability • Overhauling load | <ul style="list-style-type: none"> • Check the motor, gain, and stability parameters. • Add a braking resistor. • Check the size of the motor, drive controller, and load. |
| <i>t n F</i> Auto-tuning fault | <ul style="list-style-type: none"> • Motor or motor power not suitable for the drive controller • Motor not connected to the drive controller | <ul style="list-style-type: none"> • Use the L or the P ratio (see UfT on page 36). • Check the presence of the motor during auto-tuning. • If a downstream contactor is being used, close it during auto-tuning. |

Faults Which Can be Reset With the Automatic Restart Function

After the cause of the fault has been removed, the following faults can be reset:

- With the automatic restart function (Atr parameter in the FLt- menu, see the *ATV31 Programming Manual*),
- Via a logic input (rSF parameter in the FLt- menu, see the *ATV31 Programming Manual*),
- By cycling power to the drive controller.

Faults Which Can be Reset With Automatic Restart

| Fault | Probable Cause | Remedy |
|---|---|--|
| <i>LDL</i> Serial link failure CANopen | Loss of communication between drive controller and communication device or remote keypad. | <ul style="list-style-type: none"> • Check the communication bus. • Refer to the product-specific documentation. |
| <i>EPF</i> External fault | User defined | User defined |
| <i>LF</i> Loss of 4-20 mA follower | Loss of the 4-20 mA reference on input AI3 | Check the connection on input AI3. |
| <i>DBF</i> Overvoltage during deceleration | <ul style="list-style-type: none"> • Braking too rapidly • Overhauling load | <ul style="list-style-type: none"> • Increase the deceleration time. • Install a braking resistor if necessary. • Activate the brA function if it is compatible with the application. Refer to the <i>ATV31 Programming Manual</i>. |
| <i>DHF</i> Drive overload | <ul style="list-style-type: none"> • Drive controller or ambient temperature are too high. • Continuous motor current load is too high. | Check the motor load, the drive controller ventilation, and the environment. Wait for the drive controller to cool before restarting. |
| <i>DLF</i> Motor overload | <ul style="list-style-type: none"> • Thermal trip due to prolonged motor overload • Motor power rating too low for the application | Check the Ith setting (motor thermal protection, page 32), check the motor load. Allow the motor to cool before restarting. |

Faults Which Can be Reset With Automatic Restart (Continued)

| Fault | Probable Cause | Remedy |
|--|---|---|
| <p><i>D P F</i> Motor phase failure</p> | <ul style="list-style-type: none"> Loss of phase at drive controller output Downstream contactor open Motor not connected Instability in the motor current Drive controller oversized for motor | <ul style="list-style-type: none"> Check the connections from the drive controller to the motor. If a downstream contactor is being used, set OPL to OAC. Refer to the <i>ATV31 Programming Manual</i>, FLT-menu. Test the drive controller on a low power motor or without a motor: set OPL to nO. Refer to the <i>ATV31 Programming Manual</i>, FLT- menu. Check and optimize the UFr (page 32), UnS (page 35), and nCr (page 35) parameters and perform auto-tuning (page 36). |
| <p><i>D S F</i> Overvoltage during steady state operation or during acceleration</p> | <ul style="list-style-type: none"> Line voltage too high Line supply transients | <ul style="list-style-type: none"> Check the line voltage. Compare with the drive controller nameplate rating. Reset the drive controller. |
| <p><i>P H F</i> Input phase failure</p> | <ul style="list-style-type: none"> Input phase loss, blown fuse 3-phase drive controller used on a single phase line supply Input phase imbalance Transient phase fault <p><i>Note: This protection only operates with the drive controller running under load.</i></p> | <ul style="list-style-type: none"> Check the connections and the fuses. Disable the fault by setting IPL to nO. Refer to the <i>ATV31 Programming Manual</i>. Verify that the input power is correct. Supply 3-phase power if needed. |
| <p><i>S L F</i> Serial link failure Modbus</p> | <p>Loss of connection between drive controller and communication device or remote keypad.</p> | <ul style="list-style-type: none"> Check the communication connection. Refer to the product-specific documentation. |



KES ENVIRO START-UP REPORT

General Information

| | | | |
|----------|--|----------|--|
| Job Name | | Date | |
| Location | | File No. | |
| KES No. | | Motor HP | |
| S/N | | Voltage | |

| Item | Description | Y / N |
|------|---|-------|
| 1 | Check all electrical connections. Tighten as necessary | |
| 2 | Check for power to the RPD-KD panel on terminals 1 & 4 | |
| 3 | Check all remote wiring to ensure it has been connected | |
| 4 | LV10 J-Box wiring to terminal 1, 4 & 5 from RPD-KD remote | |
| 5 | LV10 J-Box wiring to terminal 4 & 5 to exhaust fan motor starter mounted on KES | |
| 6 | LV10 J-Box wiring to odor spray 4 & 17 (Optional for odor spray units) | |
| 7 | Power wiring to disconnect switch | |

Check if all filters are in the unit

| Type of Filter | Size | Qty |
|----------------|------------|-----------------|
| 8 | Prefilter | 12" x 24" x 2" |
| 9 | Prefilter | 24" x 24" x 2" |
| 10 | Bag Filter | 12" x 24" x 22" |
| 11 | Bag Filter | 24" x 24" x 22" |
| 12 | Box Filter | 12" x 24" x 12" |
| 13 | Box Filter | 24" x 24" x 12" |

| Item | Description | Y / N |
|------|---|---------|
| 14 | Check of the inlet exhaust ductwork to the KES unit from the kitchen exhaust hood is all welded NFPA-96 | |
| 15 | Check if clearance to top, sides, and ends of KES filter box is available: 18" to combustible or 6" to non-combustibles | |
| 16 | Check power at disconnect switch | 3/60/ V |

| Item | Description | Y / N |
|------|--|-------|
| 17A | <p>Non VFD units:</p> <p>Check fan rotation as follows: Turn on the main disconnect to the KESF fan motor starter Turn "FAN ON" switch in the wash panel or remote RPD-KD panel to the ON position Turn on the Override switch in the RPD-KD or RPD-KW remote panel. The LOGO text message "Service Filters within 4 hours" will appear. Turn "FAN OFF" switch in the wash panel or remote RPD-KD panel to the OFF position. Observe the fan rotation. Change one of L1, L2 or L3 if fan is rotating backwards AFTER DISCONNECTING ALL POWER TO THE KESF UNIT.</p> | |
| 17B | <p>VFD units:</p> <p>Check fan rotation as follows: Turn on the main disconnect to the KESF fan motor starter Turn "FAN ON" switch in the wash panel or remote RPD-KD panel to the OFF position Put a jumper wire between terminals A and B in the LV20 panel. The fan will rotate for the length of time the jumper wire is in place. Observe the fan rotation. To correct fan rotation switch two of the high voltage wires on terminals U/T1, V/T2 or W/T3 on the drive or switch two wires at the motor. AFTER DISCONNECTING ALL POWER TO THE KESF UNIT.</p> | |

| | | | | |
|-----|---|---------------------------------------|----|----|
| 18 | Turn "FAN ON" switch in the wash panel or remote RPD-KD panel to the ON position | | | |
| 19A | Non VFD Unit: Check the FLA | L1 | L2 | L3 |
| 19B | VFD Unit: Check the FLA For Lenze VFD check parameter P508 for Altivar 312 check menu SUP parameter LCr | P508 = _____ Amps LCr = _____ Amps | | |
| 20A | NON-VFD unit: Adjust the overload setting on motor starter to FLA rating of motor | | | |
| 20B | VFD unit: The variable speed drives have a factory set overload setting | | | |

Alarm Circuit Check

| | | |
|----|--|--|
| 21 | Turn "FAN OFF" switch in the wash panel or remote RPD-KD panel to the OFF position | |
| 22 | Rotate the OVERRIDE switch on the RPD-KD or RPD-KW to the original position. The text message will disappear once the fan is turned back on. | |
| 23 | Turn "FAN ON" switch in the wash panel or remote RPD-KD panel to the ON position | |

Pre filter Clogged Test

| | | | |
|----|---|-----|----|
| 24 | Jumper terminals 1 & 12 in the LV10 panel | | |
| 25 | KES unit shuts off | Yes | No |
| 26 | Prefilter clogged light on and LOGO text message "Change Prefilter" | Yes | No |
| 27 | Rotate the OVERRIDE switch on the RPD-KD or RPD-KW on and off. | | |
| 28 | Rotate "FAN ON" switch to OFF and then to ON to reset the unit. | | |

Bag Filter Clogged Test

| | | | |
|----|--|-----|----|
| 29 | Jumper terminals 1 & 13 in the LV10 panel | | |
| 30 | KES unit shuts off | Yes | No |
| 31 | Bag clogged light on and LOGO text message "Change Bag filter" | Yes | No |
| 32 | Rotate the OVERRIDE switch on the RPD-KD or RPD-KW on and off. | | |

Box filter Clogged Test

| | | | |
|----|--|-----|----|
| 33 | Jumper switch terminals 1 & 14 in the LV10 panel | | |
| 34 | KES unit shuts off | Yes | No |
| 35 | Box clogged light on and LOGO text message "Change Box Filter" | Yes | No |
| 36 | Rotate the OVERRIDE switch on the RPD-KD or RPD-KW on and off. | | |

Filter Removed Test

| | | | |
|----|---|-----|----|
| 37 | Jumper switch terminals 1 & 15 in the LV10 panel | | |
| 38 | KES unit shuts off | Yes | No |
| 39 | Filter removed light on and LOGO text message "Filter Out or Low Exhaust" | Yes | No |
| 40 | Rotate the OVERRIDE switch on the RPD-KD or RPD-KW on and off. | | |

Actual Filter pressure readings (See page 47 for description of how to read various pressure on LV10 PCL)

| | | | | |
|----|-------------------|--|-----------|--|
| 41 | Read the PRE C Ax | | PRE O OFF | |
| 42 | Read the BAG C Ax | | BAG O OFF | |
| 43 | Read the BOX C Ax | | BOX O OFF | |

Filter Out Test #1

| | | | |
|----|--|-----|----|
| 44 | Remove all the bag filters. Shut the access door and turn the unit on. Wait for 30 sec. | | |
| 45 | KES unit shuts off | Yes | No |
| 46 | Filter removed light on and LOGO text message “Filter Out or Low Exhaust” | Yes | No |
| 47 | Reset unit at LV10 J-Box reset switch by turning on and off | | |
| 48 | If the unit does not shut off adjust the BAG O OFF setting below the BAG O Ax reading. See page 47 of manual for description of changing the BAG O OFF setting. Once setting has been adjusted repeat item 44. | | |

Filter Out Test #2

| | | | |
|----|--|-----|----|
| 49 | Remove all the box filters. Shut the access door and turn the unit on. Wait for 30 sec. | | |
| 50 | KES unit shuts off | Yes | No |
| 51 | Filter removed light on and RPD-KD or RPD-KW LOGO text message “Filter Out or Low Exhaust” | Yes | No |
| 52 | Rotate the OVERRIDE switch on the RPD-KD or RPD-KW on and off. | | |
| 53 | If the unit does not shut off adjust the BOX O OFF setting below the BOX O Ax reading. See page 47 of manual for description of changing the BOX O OFF setting. Once setting has been adjusted repeat item 44. | | |

Hi Temperature Switch Test

| | | | |
|----|--|-----|----|
| 54 | Jumper terminals 1 & 16 in the LV10 J-Box. | | |
| 55 | KES unit shuts off | Yes | No |
| 56 | Fire light on | Yes | No |
| 57 | Rotate the OVERRIDE switch on the RPD-KD or RPD-KW on and off. | | |

Check override switch

| | | | |
|-----|---|-----|----|
| 58 | Turn “FAN OFF” switch in the wash panel or remote RPD-KD panel to the OFF position | | |
| 59 | Jumper terminals 1 & 12 in the RPD-KD or RPD-KW. | | |
| 60 | Turn “FAN ON” switch in the wash panel or remote RPD-KD panel to the ON position | | |
| 61 | After 30 seconds the KES shuts off, the Prefilter Clogged light turns on and the LOGO text message “Prefilter Clogged” will appear. | | |
| 62 | Rotate the OVERRIDE switch on the RPD-KW or RPD-KD remote panel to the ON position. | | |
| 63 | KES unit turns on | Yes | No |
| 64 | Warning light turns on and the LOGO text message “Service Filters within 4 hours” will appear. | Yes | No |
| 65 | Turn “FAN OFF” switch in the wash panel or remote RPD-KD panel to the OFF position | | |
| 66 | Remove the jumper | | |
| 67 | Turn “FAN ON” switch in the wash panel or remote RPD-KD panel to the ON position | | |
| 68 | Rotate the OVERRIDE switch on the RPD-KW or RPD-KD remote panel to the OFF position. The Warning light goes off and the LOGO text message disappears. | | |
| 69 | Measure the exhaust air volume at each hood Use hood start up form for this. Adjust air volume to suit with change of pulleys. | | |
| 70A | Non-VFD Units: To adjust fan speed, check with Spring Air Engineering to determine if sheaves can be adjusted or changed to increase or reduce as needed. | | |
| 70B | VFD units: To adjust fan speed, check with Spring Air Engineering to determine if VFD can be sped up or slowed down. Adjust Parameter P103 for maximum speed setting on Lenze drives. For Altivar 312 VFD’s adjust HSP in SET menu for maximum speed. | | |
| | | | |
| | | | |

Comments:

Service Technician: _____

Yes I have received a set of Spring Air Systems Inc. maintenance manuals.

Signature _____ Print Name _____